

Design and Development of a Special Purpose Bidirectional Mixer to Maximize Agitating Performance

Dattatraya P. Patil

Associate Professor
PVPIT, Budhgaon, Maharashtra, India
dattatrayap_patil@yahoo.com

Vishal P. Patil

Assistant Professor
PVPIT, Budhgaon, Maharashtra, India
vishalpp18@gmail.com

Amod P. Shrotri

Associate Professor
PVPIT, Budhgaon, Maharashtra, India
amod_shrotri@rediffmail.com

Nikhil S. Mane

Assistant Professor
PVPIT, Budhgaon, Maharashtra, India
manenikhil24@gmail.com

Abstract: *Mixing is very important operation in any process industry. All operations involving liquid phase reactions, blending homogenization, emulsion preparation, dissolution, extraction, etc., need mixing in one form or the other. Mixing of powders, pastes, paints jellies and many other products is needed to be done in many industries for many applications; it can be done by the rigorous shaking and creating turbulence in the contents. The process is called as agitation for which directionally reversible mixtures are utilized. These reversible mixers Can give partial homogenization for more effective homogenization it is needed to design of a special purpose machine which gives cyclic reversal of the rotor and create more effective agitating turbulence. This project is about such a special purpose dynamic mixer designed and developed for a paint manufacturing industry .In this paper, the design and development of this machine is discussed in details, the results of this work are encouraging and giving better agitating performance over conventional method.*

Keywords: *Agitator, Mixers, special purpose machines, Bidirectional mixer.*

1. INTRODUCTION

In case of process industries, process of mixing, stirring forms and the important part of the total manufacturing process. Mixing is the process which determines uniformity and overall quality of product.

Process industries like chemical plants, food processing plants, paint industry etc, largely employ mechanical mixers to carry out mixing of powders , semisolid jelly fluids etc. Mixing is a process where powder or jellies are mixed together through in the form of uniform mixture where stirring is the process to mix the fluid and powder to dissolve the powder thoroughly in given mixture and form a uniform product or output. In either of above cases thorough mixing of material is desirable to give and good and uniform quality output. Mixing of powders of different material in order to form a uniform product or a powder mix is quiet easy but when it is desirable to mix powder in a fluid matter specially when the density of powder is high the problem occurs due to heavy weight of particles of powder has a tendency to settle down.

In this case it is required to mix the heavy density metal powder in the fluid mixture and pigment base together called as in vehicles .Vehicle is a low density evaporative fluid which when mixed with metal oxide powder thoroughly is applied by spray painting on to automobiles silencer to form an anticorrosion particle layer. In order to have good quality and uniform layer of paint on the job it is necessary that the oxide powder is thoroughly mixed with vehicles. It can be done by the rigorous shaking and creating turbulence in the contents. The process is called as agitation for which directionally reversible mixes are utilized. These reversible mixers can give partial homogenization, for more effective homogenization it is needed to design of a special purpose machine which gives cyclic reversal of the rotor and create more effective agitating turbulence.

2. AGITATION AND MIXING OF FLUIDS

For more effective homogenization it is needed to rigorously shake and create turbulence in the contents. The process is called as agitation.

Purpose of agitation is intensification of transport processes in agitated batch in case of heat and mass transfers oriented processes and preparation of materials of required properties like suspensions, emulsion etc. in process industries. Few examples of agitation and mixing are as shown below;

Examples and industrial applications of agitation and mixing process:

- Blending of two mixable liquids like alcohols and water / any solvent
- Dissolving solids into liquids like salts and water
- Liquid to liquid dispersion like dispersion of pigments in suitable vehicles
- agitation of the fluid to increase heat transfer between the fluid and a coil or jacket in the vessel wall
- Suspending of fine solid particles in a liquid like suspending fine color powders in vehicles in oil paints etc.

3. RELEVANCE

The stirrer of conventional machine rotates in one direction only which creates a particular flow pattern in the fluids hence the particles tend to stick to the walls of container owing to the centrifugal force rather than mixing thoroughly in mixture of paint, ultimately results into poor quality mixture of paints there by poor quality output of paint.

In order to have a through mixing of metal oxide powder it would be appropriate to have a directions of rotation of stirrer shaft which will rotate stirrer blades in opposite directions in one cycle this will form turbulent flow pattern there by leading to creation of irregular flow pattern and resulting into thoroughly mixed paint mixture preparation which will create the good quality paint.

The bidirectional mixer is an ideal solution to the above problem where in the mixer fan oscillates bi-directionally, as well as moves in the to and fro manner along vertical axis hence generates sufficient turbulence for thorough mixing and excellent quality of mixture.

In order to have a through mixing of metal oxide powder it would be appropriate to have a directions of rotation of stirrer shaft which will rotate stirrer blades in opposite directions in one cycle this will form turbulent flow pattern there by leading to creation of irregular flow pattern and resulting into thoroughly mixed paint mixture preparation which will create the good quality paint.

The bidirectional mixer is an ideal solution to the above problem where in the mixer fan oscillates bi-directionally, as well as moves in the to and fro manner along vertical axis hence generates sufficient turbulence for thorough mixing and excellent quality of mixture.

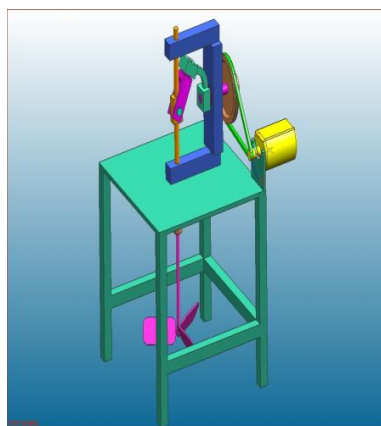

Fig1. Bidirectional Mixer Machine

4. CONSTRUCTION AND WORKING

The spatial agitator consists of an basic mechanism that produces an oscillating motion from continuously rotary input. The mechanism as shown in the figure is developed to produce an oscillating motion in the vertically suspended output shaft trough the continuously rotating horizontal input shaft'. The input shaft carries an input crank that engages with input shaft at one end and the fork at other. The fork is coupled to output shaft by means of fork pin. During 0 to 180 degree rotation

of the input shaft the crank and the fork together make output shaft to rotate in clockwise direction by 60 degrees, whereas during 180 to 360 degrees of input the output changes direction and returns to mean position. The motor is bolted to the base plate mounted on the base frame

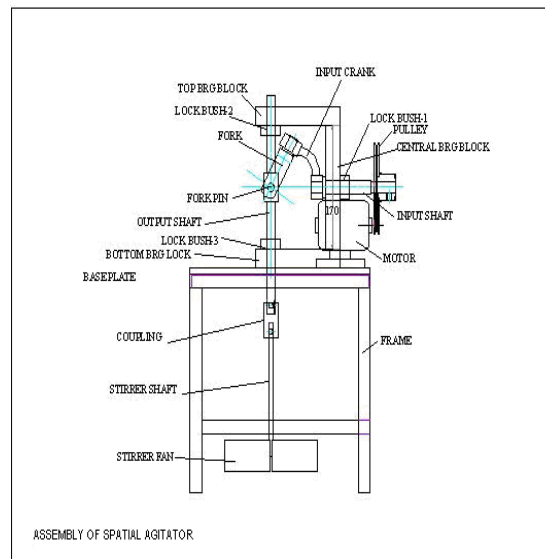

Fig2. Design of Bidirectional Mixer Machine

5. SYSTEM DESIGN

In system design we mainly concentrated on the following parameters:

➤ System Selection Based on Physical Constraints

While selecting any machine it must be checked whether it is going to be used in a large-scale industry or a small-scale industry. In our case it is to be used by a small-scale industry. So space is a major constrain. The system is to be very compact so that it can be adjusted to corner of a room.

The mechanical design has direct norms with the system design. Hence the foremost job is to control the physical parameters, so that the distinctions obtained after mechanical design can be well fitted into that.

➤ Arrangement of Various Components

Keeping into view the space restrictions the components should be laid such that their easy removal or servicing is possible. More over every component should be easily seen none should be hidden. Every possible space is utilized in component arrangements.

➤ Components of System

As already stated the system should be compact enough so that it can be accommodated at a corner of a room. All the moving parts should be well closed & compact. A compact system design gives a high weighted structure which is desired.

➤ Man Machine Interaction

The friendliness of a machine with the operator that is operating is an important criteria of design. It is the application of anatomical & psychological principles to solve problems arising from Man – Machine relationship. Following are some of the topics included in this section.

- Design of foot lever
- Energy expenditure in foot & hand operation
- Lighting condition of machine.

➤ Chances of Failure

The losses incurred by owner in case of any failure is an important criteria of design. Factor safety while doing mechanical design is kept high so that there are less chances of failure. Moreover periodic maintenance is required to keep unit healthy.

➤ Servicing Facility

The layout of components should be such that easy servicing is possible. Especially those components which require frequent servicing can be easily disassembled.

➤ Scope of Future Improvement

Arrangement should be provided to expand the scope of work in future. Such as to convert the machine motor operated; the system can be easily configured to required one. The die & punch can be changed if required for other shapes of notches etc.

➤ Height of Machine from Ground

For ease and comfort of operator the height of machine should be properly decided so that he may not get tired during operation. The machine should be slightly higher than the waist level, also enough clearance should be provided from the ground for cleaning purpose.

➤ Weight of Machine

The total weight depends upon the selection of material components as well as the dimension of components. A higher weighted machine is difficult in transportation & in case of major breakdown, it is difficult to take it to workshop because of more weight.

6. COMPONENT DESIGN

Input Data

- Kinematic viscosity of Paint = 2.4 poise
= 2.4/0.01 centipoise
= 240 centipoise
- Specific gravity of paint = 1.59 kg/lit

In design of spatial agitator the approach to design would be to calculate the torque required at the output shaft for stirring, and based on this torque selecting an appropriate motor; after incorporating a suitable factor of safety.

The torque calculation will be based on two analogies namely; torque required to overcome the viscous force by virtue of the fluid viscosity and secondly the torque required to overcome the static total pressure on each blade owing to the stationary fluid ie, paint.

6.1. Calculation of Torque Owing to Viscous Force at Periphery of Blades

In calculation of the viscous force we use the following analogy;

The blade tip traces a loci of points which is a circle ; hence the motion of the bracket due to oscillation of the output shaft can be considered to be a cylinder (assuming blade angle =0°), which is moving against another cylinder ie, the container both separated by a fluid film of thickness of 30 mm.

We can put up the above problem as follows;

$$\mu = 2.4 \text{ poise} = 1/10 * 2.4 = 0.24 \text{ Ns/m}^2$$

Speed of shaft = 80 rpm

$$\begin{aligned} \text{Tangential speed of shaft} = u &= \pi DN/60 \\ &= \pi \times 0.10 \times 80/60 \\ &= .0418 \text{ m/sec} \end{aligned}$$

Now,

$$\tau = \mu \text{ du/dy}$$

where;

$$\tau = \text{Shear stress (N/m}^2\text{)}$$

$$du = \text{Change in speed} = u - 0 = 0.418 \text{ m/sec}$$

$$dy = \text{Distance between shaft and journal} = 0.01 \text{ m}$$

$$\tau = 0.24 \times 0.418 / 0.01 = 10.032 \text{ N/m}^2$$

Area of the cylinder that is exposed to this shear intensity will be the circumferential area; (assuming width of blade = 40 mm)

$$A = c \times D \times w = \pi \times 0.1 \times 0.04 = 0.012 \text{ m}^2$$

$$\text{Shear force (F)} = \text{Shear stress} \times \text{Shear area}$$

$$= 10.032 \times 0.012$$

$$= 0.126 \text{ N}$$

$$\text{Power} = F \times u = 0.126 \times 0.418$$

$$= 0.0526 \text{ Watt}$$

6.2. Calculation of Torque Owing to Viscous Force at Top and Bottom Ends of Blades

In calculation of the viscous force we use the following analogy;

The blades along the length when rotated along with bracket will trace an annular ring at the either ends of the blade.

We can put up the above problem as follows;

$$\text{Given: } \mu = 2.4 \text{ poise} = 1/10 \times 2.4 = 0.24 \text{ Ns/m}^2$$

$$\text{Speed of plate} = 0.418 \text{ m/sec}$$

Now,

$$\tau = \mu \frac{du}{dy}$$

where;

$$\tau = \text{Shear stress (N/m}^2\text{)}$$

$$du = \text{Change in speed} = u - 0 = 0.418 \text{ m/sec}$$

$$dy = \text{Distance between shaft and journal} = 0.01 \text{ m}$$

$$\tau = 0.24 \times 0.418 / 0.01 = 10.032 \text{ N/m}^2$$

Area of the cylinder that is exposed to this shear intensity will be

$$A = L \times B = 1 \times 0.05 = 0.05 \text{ m}^2$$

$$\text{Shear force (F)} = \text{Shear stress} \times \text{Shear area}$$

$$= 10.032 \times 0.05$$

$$= 0.528 \text{ N}$$

$$\text{Total shear force} = 3 \times F = 1.584 \text{ N}$$

$$\text{Power} = F \times u = 1.584 \times 0.418 = 0.662 \text{ Watt}$$

6.3. Calculation of Torque Owing to Static Total Pressure Acting on the Blades by Virtue of The Stationary Fluid

In calculation of torque due to static force exerted by the fluid we use the following analogy;

$$\text{Given: sp gr.} = 1.59 \text{ kg / lit} = 1.59 \times 1000 \text{ kg/m}^3$$

Total pressure is given by;

$$F = \rho g A h$$

$$= 1590 \times 9.81 \times 0.05 \times 0.04 \times 0.1$$

$$= 3.115 \text{ N}$$

There are three such blades,

Thus the total force = $3 \times 3.115 = 9.35 \text{ N}$

The torque that each pinion has to overcome to rotate about its own axis is given by;

$$T = 9.35 \times 0.04 \\ = 0.374 \text{ N-m}$$

Power required at the output shaft to overcome the static resistance of fluid is ,

$$P_s = 2\pi NT_s/60 \\ = 2 \times 3.142 \times 80 \times 0.374/60 \\ = 3.13 \text{ Watt}$$

Thus the net power required at the output shaft is the summation of the above three powers;

$$P_{\text{net}} = 0.0526 + 0.662 + 3.13 = 3.8446 \text{ Watt approximately 4 watt}$$

The mechanism used for converting rotary power into oscillatory energy is not tested for its efficiency so assuming only 50% efficiency and assuming that further power is lost in friction at the bush bearings we shall assume overall efficiency to be 30 % only thus power required by machine will be 28 watt approximately. As we intend to run machine at various speeds hence we shall employ an commutator motor speed of which can be varied by placing an rheostat in series.

7. CONCLUSIONS

In the development of this bidirectional stirrer mixer many changes are done in conventional design of mixer. The results of this work are encouraging and giving better agitating performance over conventional method. This bi- directional mixer rotates in both directions and it gives better agitating effecting in more uniform mixture of product. It is observed that the quality of mixture is very high. As it requires no gear box its production cost is very low as compare to the conventional mixture. The cost also reduced by compact size of mixture which leads to low space requirement. This new developed mixer has low cost, high performance and structural simplicity.

REFERENCES

- [1] Saeed Asiri, et al., "Design and Implementation of Differential Agitators to Maximize Agitating Performance" *International Journal of Mechanics and Applications*, 2012, 2(6): 98-112.
- [2] saurabh Kumar, Gopi Chattopadhyay, Uday Kumar, "Reliability Improvement through Alternative Designs-A Case Study." *Reliability Engineering and System Safety*, Page no.983-991, February 6, 2007.
- [3] L. Y. Waghmode, R. B. Patil, "An Overview of Fault Tree Analysis (FTA) Method for Reliability Analysis." *Journal of Engineering Research and Studies*, Volume 4, Page no. 6-8, January 2013.
- [4] Tomas Jirout, et al "Impeller Design for Mixing of Suspension". Czech Technical University in prague, Faculty of Mechanical Engineering, department of Process Engineering, (2011) 1144–1151
- [5] E.Rajasekaran, et.al. "Agitator and Wiper Design Modification for Milk Khoa Machine" *International Journal of Innovative Research in Science, Engineering and Technology*, Volume 3, Special Issue 1, February 2014
- [6] Inoue Takao and Saito Makoto, "mixing device and method" kajima corp JP (1999).
- [7] Hockmeyer and Herman H, "Apparatus for dispersing solid constituents into a liquid" hockmeyer equipment corp (2006)
- [8] Kevin Otto, Kristin Wood, "Product Design: Techniques in reverse engineering and New Product development", Pearson Education, ISBN:81-297-0271-1, First Edition, 2004
- [9] M.V Joshi's *Process Equipment Design* , 4th ed., V.V. Mahajani.,S.B.Umarji Mumbai, 2009

AUTHORS' BIOGRAPHY



Prof. D. P. Patil is graduate in mechanical engineering and post graduation in M.E. (Mechanical-Design Engg.). He has teaching experience of 27 years at P.V.P.I.T.BUDHAON, Dist. Sangli, Maharashtra, INDIA since 1986. He has specialization in mechanical design engineering. He has published ten papers in international journals.



Prof. A.P. SHROTRI is working as an Associate professor in P.V.P.I.T. BUDHAON, Dist. Sangli, Maharashtra, INDIA since 1986. He is a graduate in Mechanical Engineering, and a post graduate in mechanical Engineering, with specialization in Production Engineering. He has a remarkable teaching experience of 29 years. He has published fifteen papers at national level workshops and seventeen papers in international journals. He is the editorial board member of six international journals and worked as and on the board of reviewers of nine international journals.



Prof. Vishal P. Patil is M. Tech (Mechanical Design) and has 3 years teaching experience. His research area is desing and energy engineering. He is assistant professor at P.V.P.I.T.BUDHAON, Dist. Sangli, Maharashtra, INDIA since 2012.



Prof. Nikhil S. Mane completed his ME in Heat-Power (Mechanical) Engineering. His research areas are power engineering and refrigeration and air conditioning systems. He is working at P.V.P.I.T.BUDHAON, Dist. Sangli, Maharashtra, INDIA since 2013.