



Comprehensive Study & Overview of Neural Networks for Classification of Diseases

Shashikant Patil^{1*}, Pravin Wararkar², Dhananjay Joshi³, Ashish Awate⁴

¹Department of Electronics & Telecommunication Engineering (Associate Professor) SVKM's NMIMS (Deemed-to-be-University) Mukesh Patel School of Technology Management & Engineering, Shirpur, India

²Department of EXTC Engineering (Assistant Professor) SVKM's NMIMS(Deemed-to-be-University) Mukesh Patel School of Technology Management & Engineering, Shirpur, India.

³Department of Computer Engineering (Assistant Professor) SVKM's NMIMS(Deemed-to-be-University) Mukesh Patel School of Technology Management & Engineering, Shirpur, India.

⁴Department of Information Technology (Assistant Professor); Dr. Babasaheb Ambedkar Technological University, Lonere, SVKM's Institute of Technology, Dhule. India.

***Corresponding Author: Shashikant Patil**, Department of Electronics & Telecommunication Engineering (Associate Professor) SVKM's NMIMS (Deemed-to-be-University) Mukesh Patel School of Technology Management & Engineering, Shirpur

Abstract: The conventional computing techniques are good at performing fast arithmetic and computations as per programme's instruction set in the program. But conventional computing is not so good to interact with noisy data or data from the environment, massive parallelism, fault tolerance, and adapting to circumstances. In same scenario the classification of diseases are discussed and addressed in this paper. Here the noisy data with high level of parallelism is considered and we always need to adapt it as per circumstances and situations based on applications. So it becomes difficult to adapt conventional computing for classification of diseases. On other hand the neural network (NN) systems usage for formulation of algorithm and provide the solutions is efficient and faster. Also NNs has capabilities to extract meaningful information from highly complicated data, and it can be used to predict the patterns or to analyse trend in complex scenario which can't picked by humans or by other conventional computing. When NN get fully trained it will be considered as expert for particular information that it has been given to analyse. In this paper we have carried a comprehensive assessment and performance overview of Neural Networks for Classification of Diseases. This can be used in densely populated countries or areas having lack of medical facilities are very difficult to classify the disease of patients at the earliest and prescribe the proper treatment on the basis of correct diagnosis. In practice, classification of diseases is a tedious and cumbersome task in terms of computation. On the basis of capabilities of Neural network, in this paper we have addressed overviewed and studied comprehensively why, what, when, where, who, and how one can classify disease effectively using ANN?

Keywords: Neural networks, ANN, Emotion Mining, Computation, Disease Classification.

1. INTRODUCTION

1.1. Biological Neural Network (BNN)

The neural network is actually deduced from the biological neural network. So first we see the structure of biological neural network. Human brain consists of a millions of neural cells that process information. Each cell considered as simple processor. Multitasking in the brain system is possible only because of massive interaction between all cells and their parallel processing. Neuron is the elementary nerve cell and is the fundamental building block of the biological NN. Diagrammatical it can be represent as shown in fig 1.1 & 1.2. A typical neuron consists of three major regions: Soma i.e. the cell body, the Axon and Dendrites [1] [2].

Branching fibres that came out from cell body is called as dendrite and which is communication link between two neurons. Soma or cell body consists of the nucleus and other structures which supports chemical processing and production of neurotransmitters. Long singular fibre carries information

away from the soma to the synaptic sites of other neurons is called Axon. Incoming information get summed at Axon hillock. To protect axon from electrical activity there is fat insulation called Myelin Sheath. This insulation acts to increase the rate of transmission of signals. There is gap exists between each myelin sheath called Nodes of Ranvier (about 1 μm). The signal jumps from one node of Ranvier to another since fat inhibits the propagation of electricity. Due to this the myelin sheaths speed the rate of transmission of an electrical impulse along the axon. The point of connection between two neurons is called as Synapse. They are works as junction for electrochemical communication between neurons. The small knobs at the end of an axon are nothing but terminal button of neuron that release chemicals called neurotransmitters [3][4][5].The generated neurotransmitters affects the receiving neuron, which on receiving either generates an impulse to its axon, or produces no response.

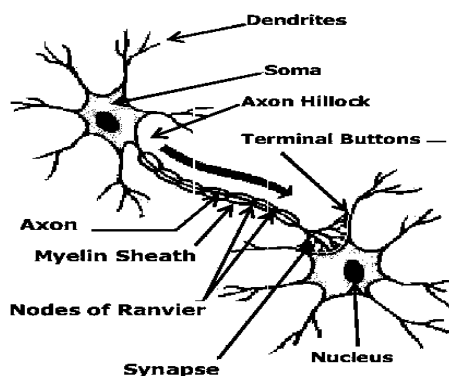

Fig1.1. Component of Neuron

How the Human Brain Learns?

This section will enlighten how our brain learns? i.e. taking input and gives proper output. Which is diagrammatically shown in fig 1.2. In the human brain, dendrites are at receiving end of neuron which receive activation signal from other neurons. Incoming activation signal is then processed by soma and converts that signal into output activations and handover it to axon. The summed signal at axon hillock is then transferred along with axons which consider as transmission lines for sending activation signal to other neuron through synapse. Synapses are nothing but the structure presents at end of split branches of an axon. Synapses usually convert the activation signal from the axon into electrical effects that inhibit or excite in the connected neurons. Neuron sends spike of electrical signal to its axon if and only if it receives excitatory input which has to be sufficiently large as compared to its inhibitory input.

Therefore, Synapses are the junction which allows signal transmission from the axons towards dendrites of other neuron. Due to diffusion of a chemical called neuro-transmitter the process of transmission is took place. Whenever the influence of one neuron on another neuron changes it changes the effectiveness of of the synapses and as a result learning takes place [1][4][5].

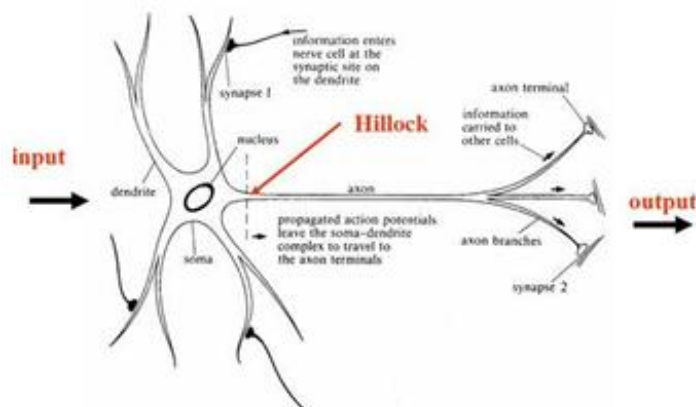

Fig1.2. Structure of a neural cell in the human brain

1.2. Artificial Neural Network (ANN)

In broad prospect, the network which has capabilities to acquire, store and utilize experimental knowledge is called Artificial Neural Networks (ANN). ANNs has been related to the network's capabilities and performance. In the structural view the ANN can be defined as a network in which the output of neurons are connected to all other neuron including themselves with the help of weights to form an interconnection of neuron in which lag-free as well as delay connections are allowed[2][3]. Neural Network or simply Neural Net are the nomenclatures might used instead of artificial neural network (ANN). When human neuron represents artificially and can have ability to simulate the leaning process same as that human neuron then it is an ANN. For information processing NN uses a mathematical model or computational model depending on approach adopted by programmer. It share some properties of biological NNs. ANN is flexible i.e. one can configured neural network through learning process for a specific application e.g. pattern recognition or data classification [1][6].

1.2.1. From Human Neurons to Artificial Neurons

An artificial neuron is a precise function which considers as a simple model of a biological neuron. The fig 1.3 shows a simplified model of real neurons, known as a Threshold Logic Unit. Like dendrites in biological neuron ANN consist of set of input connections which takes output of other neuron and activate the current neuron. Set of inputs then forwarded to processing unit which resembles to the cell body i.e. soma, that sums the inputs and then applies a non-linear activation function (i.e. squashing / transfer / threshold function) on it. After application of activation function on weighted sum of input the output is generated which we can think as axon of neuron. At the end the output will be will transmits to other neurons. And process continues unless and until each neuron present in system gets activated or influenced [2].

In other words,

Signal is consider as input. Cell builds up the inputted signal. At last cell fires in form of output.

Again the cell stars rebuilding a new signal as per demand.

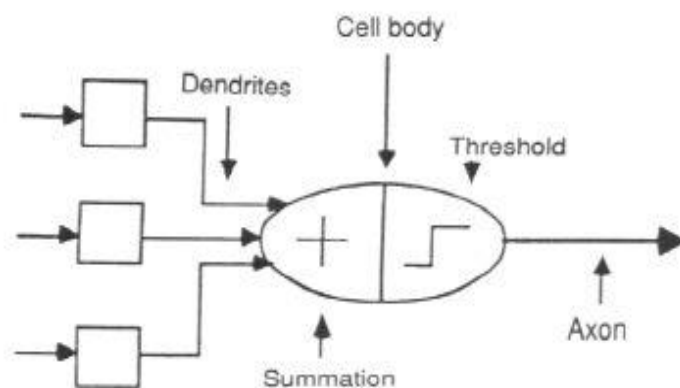

Fig1.3. The neuron model

1.2.2. A Simple Neuron

An artificial neuron is a device with multiple inputs and single output as shown in fig 1.4; it can operate in two mode: the training mode and the using mode.

- In the training mode, we can train the neuron whether to fire or not on the basis of occurrence of predefined pattern of input.
- On the other side in the using mode, neuron always fire if it found pre-agreed or expected input pattern is at the input unit as a result it consider its associated output as the current output. If the input pattern does not belonging the expected list of input patterns then the firing rule is used to determine whether neuron will fire or not [4].

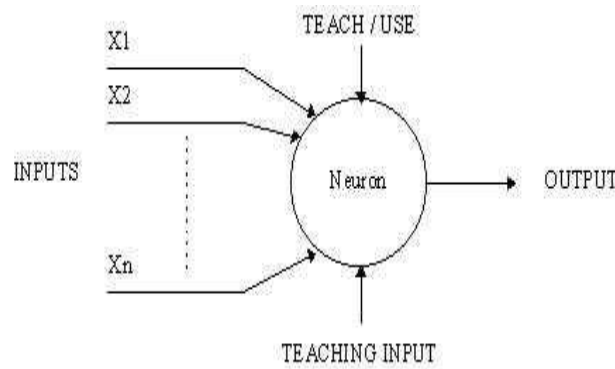

Fig1.4. A simple neuron

1.2.3. Architecture of Neural Networks

An Artificial Neural Network (ANN) it is a network structure of simple highly interconnected processing elements known as artificial neurons which mainly do a data processing system, and can be represented by directed graph as shown in fig 1.5.

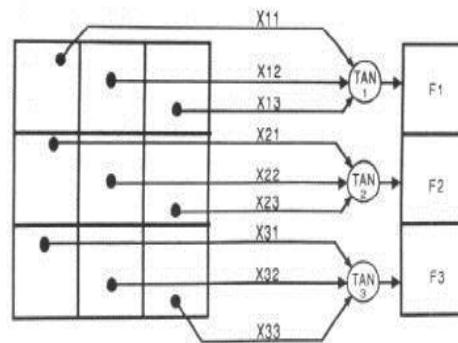

Fig1.5. Architecture of neural networks

- Feed-Forward Networks

Feed-forward ANNs (figure 1.6) is neural network with unidirectional traversing of signal say from input to output with no feedback loop is allowed in formation. In other words one can say the output of any layer cannot be reversed back towards the node itself or to the input node. These types of networks are a straight forward network that has two possible types first is single layer: Feed-forward ANN in which there is one input layer connected to the single output layer. Whereas second type is Multilayer: Feed Forward layer in which there is presence of one or more intermediate layer called hidden layer [3] in between input and output layer of network. They mainly used in pattern recognition. This type of formation of networks are sometimes referred as bottom-up or top-down [3][5][6].

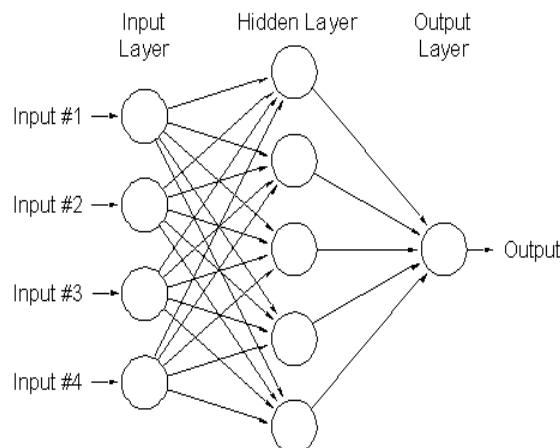

Fig1.6. Simple feed forward network (multilayer)

- *Feedback Networks*

The network in which signal can traverse in both direction due to presence of loops in networks is called Feedback networks which is shown in fig 1.7. These networks are very powerful but sometimes can get extremely complex; hence they are not popular in practice. Until and unless the equilibrium reached these networks continuously changes their state, hence these networks are considered as dynamic network. Once the equilibrium is achieved, it then remains at the equilibrium until and unless the input changes and a new equilibrium need to be achieved. This type of architectures of networks are also referred as interactive or recurrent network.[4][5].

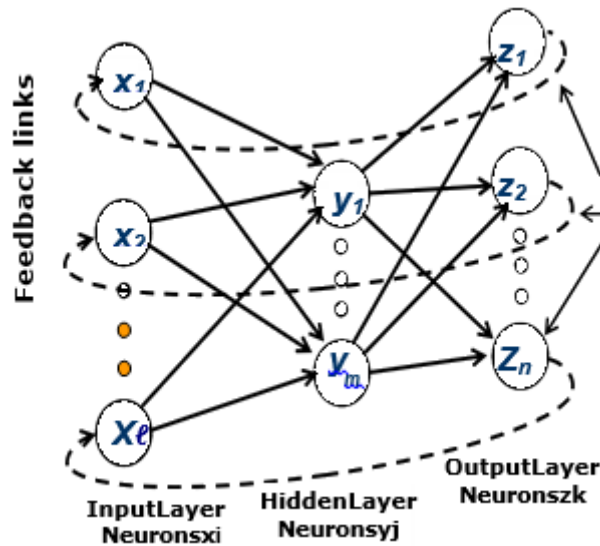

Fig1.7. Example of feedback network

- *Network Layers*

Generally typical artificial neural network consists of three groups, or layers of units: First one is input Layer, Second is Hidden layer and last is output layer. The layer are connected to each other as a layer of "input" units is connected to a layer of "hidden" units, which is then connected to a layer of "output" units (See Figure 1.6).[3]The raw information is provided to input unit of ANN and that information then served to the network as input to the network. The input to the hidden layer is calculated by taking weighted sum of inputs to the network, where weights are present on the connections between the input unit and the hidden units. The hidden layer then produces its output by using activation function I.e., sigmoid function. The weighted sum of hidden layer output determines the input to the output layer, where weights are those which present on the connections between the hidden and output units. As in this the intermediate hidden layer units are free to construct their own representations of the input due to this simple type of network gets attraction. If the desired output is not achieved the we can adjust the weights between input unit and hidden unit and followed by adjustment of weights between hidden layer and output layer, so that it can represent what we intend. We can also distinguish single-layer and multi-layer ANNs architectures [13]. The single-layer organization, in which all units are connected to each other, constitutes the most general case and is of more potential computational power than hierarchically structured multi-layer organizations. In multi-layer networks, units are often numbered by layer, instead of following a global numbering [2][3].

2. NEURAL NETWORKS VERSUS CONVENTIONAL COMPUTERS

Table1. Comparison of Statistical and neural network computation

| Task or Performance Aspect | Conventional Computation | Neural Network Computation |
|----------------------------|--------------------------|---|
| Problem solving | Formulation of Algorithm | Select the architecture followed by learning rule |
| Input Data | Numerical form | Numerical but also perceptual representation is allowed |

| | | |
|--|---|--|
| Knowledge acquisition | Through Programming | Train the network on data set |
| Knowledge retrieval | Sequential computation | Recall in the form of collective processing |
| Computation | High-precision arithmetic | Low-precision, Nonlinear mapping |
| Internal Data | Internal representation in control of the algorithm | Internal representation in control of input data |
| Fixed- or intermediate data Storage | ROM, RAM-high-precision, Binary memories | Interconnecting weights of typically continuous values |

3. HOW ARE ANN RELATED TO STATISTICAL METHODS?

Neural Network and statistics share many common characteristics. Learning from noisy data to create generalized output is called statistical inference in NN which we can resemble as data analysis in Statistics. But the NN dedicated for modelling biological systems have no concern with data analysis so they have very little to do with statistics. NN like Hopfield nets also have little to do with statistics as they do not learn. The NNs like Perceptron rule and ART would not be considered statistical methods because they learn if there is no noise in data [7][8]. Other than these most NNs are like or identical to statistical methods that can learn to generalize effectively from noisy data. In example we can take Feed forward networks without hidden layer are nothing but generalized linear models where Feed forward networks having one hidden layer very much similar to projection pursuit regression. Feed forward networks are a subclass of nonlinear regression and discrimination models Similarly Probabilistic NNs are same as kernel discriminates analysis [9]. Kohonen networks for adaptive vector quantization are closely related to k-means cluster analysis. Whereas Kohonen self-organizing maps are nothing but the discrete approximations to principal curves and surfaces.[10] Hebbian learning is similar to the principal component analysis.[11]. Statistical methods application to the feed forward NNs have been studied by Statisticians on general class but not considered the specific case of feed-forward NNs until and unless these networks were spread in the neural network field. But still we can directly apply the statistical theory of nonlinear models to feed-forward networks which were proved by many results. Methods like Levenberg-Marquardt and conjugate gradient algorithms which are commonly used for fitting nonlinear models can be used to train feed-forward networks while neural networks are often defined in terms of their algorithms or implementations, statistical methods are usually defined in terms of their results [12].

4. APPLICATIONS OF NEURAL NETWORKS

4.1. Neural Networks in Practice

In many businesses and industries NNs have already been applied effectively and provided optimal and effective solution to the many real world business problems. In the industries NN are well suited for the area like forecasting and prediction needs including :industrial process control, risk management, sales forecasting, data validation customer research and target marketing etc., because the best suited work for NN is identifying trends or patterns in data .More specifically ANN is also used in paradigms such as Three-dimensional object recognition, Hand-written word recognition, Recognition of speakers in communications, Interpretation of multi-meaning Chinese words, Undersea mine detection, Texture analysis, diagnosis of hepatitis, Recovery of telecommunications from faulty software, and Facial recognition[7][8].

4.2. Neural Networks in Medicine

In next few years market believed that in the Biomedical area ANN will receive widespread application hence currently ANNs applications related to medicine area is hot research area. Nowadays due to no need to deduce a specific algorithm for classification of diseases the research in this area are streaming towards recognizing diseases through various scans like CAT scans, cardiograms, MRI, ultrasonic scans etc. and also modelling a human body parts. To recognize diseases NNs needs the example containing all possible set of symptoms of particular disease no other things are required as NNs has property that it learn by example. In this quality of example matters not the quantity of example. Therefore it is important that the examples selection method must carried out carefully so that we can guarantee the reliability and efficiency of system [13][14].

4.2.1. Modeling and Diagnosing the Cardiovascular System

Model of individual human cardiovascular system can be modeled using ANNs. The modeled system can help in diagnosis by comparing it with patient's real time physiological measurements. We can diagnose potential harmful cardiovascular condition at initial stage if we follow this routine comparison regularly, thus it make easier to fight against the diseases [15]. An individual's cardiovascular system model must simulate and compare the physiological variables such as systolic and diastolic blood pressures, heart rate and breathing rate at different physical activity levels. Due to this ability this model, it will act as virtual expert which monitor individual's cardiovascular fitness without physical presence of expert [20].

Sensor fusion is another reason which validates the use of ANN technology in medical modelling. Sensor fusion is nothing but the combining of values from several different sensors and gives the ability to ANNs to learn complex relationships among the individual sensor values, which would otherwise be lost if the values were individually analyzed. In medical Diagnosis and modeling ANNs has capability to identify complex medical condition with the help of data fusion of individual biomedical sensor even though each sensor in a set may get sensitized on the activation of a specific physiological variable[8][15].

4.2.2. Electronic Noses

Experimentally implementation of Electronic nose is another area in which ANNs are quite useful. It is a device which useful to detect odors or flavors. It work artificially same as that of human olfaction and are capable to performed reproducing human senses using sensor arrays and pattern recognition systems by following stages such as identification, comparison, quantification and also it is capable of data storage and retrieval for respective odors or flavors. Therefore this can be used in remote surgical environment where it provides identification odors electronically which enhance tele present surgery. It also has wide applicability in Telemedicine. It is also helpful for detection of contamination, spoilage, adulteration [16].

4.2.3. Instant Physician

Instant physician is application developed in mid 80s. This application trained on store large number of patient's medical record which include information like symptoms diagnosis and treatment for individual case using auto associative memory After training, the NN can be presented with input consisting of a set of symptoms; it will then find the full stored pattern that represents the "best" diagnosis and treatment [7][8].

4.3. Neural Networks in Business

The general areas of businesses in which NN is applicable is accounting or financial analysis. Almost all NN application would fit into business area or financial analysis. Also the specific purpose in business such as scheduling or resource allocation can also solved by NN. Also in Business there is most important area to explore or which one can consider as critical for business success is to identifying the trends in businesses that can explored by NN by mining databases.. Most work is applying NNs, such as the Hopfield-Tank network for optimization and scheduling [17].

4.3.1. Marketing

In term of businesses the marketing is another area where NNs has wide applicability. The best suited example for this is a artificial intelligent computer system developed for airlines incorporated with expert system called the Airline Marketing Tactician (AMT). This system is basically developed to assist the intelligent marketing and control over airline seat allocation which is integrated with feed forward NN and trained using back-propagation network. The success story behind this application is that it used it uses adaptive neural approach was acquiescent to fetched rule expression hence it able to produce adaptive solution over rapidly changing environment. Therefore this system can easily monitor and recommend booking advice which will attract user by providing such technical advantage. [18] As similar to this system we can also explore other marketing area and create intelligent NN application by integrating it with expert systems and other approaches to make a functional system. So it is noteworthy that NN can gives the proper conclusion to the area which still unexplored by integrated with different systems. Ultimately the bottom line in such system is NN[14].

4.3.2. Credit Evaluation

The Credit Evaluation is one of the NN application developed by the company named as HNC founded by Robert Hecht-Nielsen. This application increase the cost effectiveness by 27% as compare to existing system. Mortgage screening is another area where HNC developed NN application can be applicable.

The Nestor Company developed NN application called automated mortgage insurance underwriting system. This system deal with the data related to property and borrower qualification on the basis of training data of 5048 applications out of which 2597 were certified applications. This system takes approximately 1 sec processing time for single file while running on Apollo DN3000 system with 250K memory. In terms of performance this system agreed on the guarantors on 97% of the cases in conservative mode and 84% cases on the liberal model [8].

5. NEED OF RESEARCH WORK

- It removes external burden on Specialized Person.
- Proper diagnosis and exact cause of disease can be determined.
- Untrained person can diagnose diseases and can provide preliminary treatment to the patient, so that patients can get initial treatment without aid of specialized diagnosis.
- Parallelism between NN and Human Being is achieved.
- Time required for diagnosis of diseases is less.

6. CONCLUSION

From the above Comprehensive study it is clear that:

We can simulate the data-repositories of various diseases. After this, we can implement the train database for hardware realization by using DSP Tools and FPGA Tool. In other words we can fabricate IC for the same. And by using that IC we can classify the diseases directly which can remove the external burden on specialized person in this case doctors. By using the same concept we can properly diagnosis the disease and also can determine the exact cause of disease. This hardware realization also provides advantages such as untrained person can diagnose diseases and can provide preliminary treatment to the patient, so that patients can get initial treatment without aid of expert diagnosis so due to this we sufficiently reduce the delay between diagnosis and treatment and the second advantage is that Time required for diagnosis is less.

The database which we will use in this research work will be collected from authentic data depository available on internet. After getting good results on available dataset we set goal to develop our own database of different diseases and repair our own database. We can develop database through MATLAB, for instance if we want database of the cardiovascular disease then we can create it by extracting features of ECG graph of multiple patients. And then examines it on our hardware which is already trained on depository that we collected. Hence we can determine the weather patient is suffered by any cardiovascular disease and if yes, then which type of disease it is.

ACKNOWLEDGMENT

The authors would like to thank the anonymous reviewers for the many helpful comments and suggestions.

REFERENCES

- [1] "Introduction to Artificial Neural Systems" By JackenM.Zurada (j-878), sixth edition
- [2] "An introduction to neural computing" By Aleksander, I. and Morton, H. 2nd edition
- [3] "An Introduction to Neural Networks" by Kevin Gurne
- [4] "Neural Networks for Pattern Recognition" by Christopher M Bishop
- [5] "Neural Network A Comprehensive Foundation By Simon Haykins", 2nd Edition
- [6] "Neural Networks" by Eric Davalo and Patrick Naim.
- [7] Myers, R.H. (1986), Classical and Modern Regression with Applications, Boston: Duxbury Press.

- [8] Ripley, B.D. (1994), "Neural Networks and Related Methods for Classification," Journal of the Royal Statistical Society, Series B, 56,409-456.
- [9] "Probabilistic neural networks for classification, mapping, or associative memory" DFSpecht - IEEE international conference on neural networks, 1988
- [10] "Improved versions of learning vector quantization" T. Kohonen, Neural Networks, 1990 IJCNN International Joint Conference on Neural Network
- [11] "Competitive Hebbian Learning Rule Forms Perfectly Topology Preserving Maps." In: Gielen S., Kappen B. (eds) ICANN '93. Springer, London.
- [12] "The Levenberg-Marquardt Algorithm", Ananth Ranganathan Tutorial on LM algorithm, 8th June 2004
- [13] "Application of artificial neural networks to clinical medicine" WG Baxt - *The lancet*, 1995 – Elsevier
- [14] "Application of neural networks in medicine - a review" KornelPapik, Bela Molnar, Rainer Schaefer, Zalan Dombovari, Zsolt Tulassay, Janos Feher *Med SciMonit* 1998; 4(3): MT538-546
- [15] "Artificial neural network cardiopulmonary modeling and diagnosis" LJKangas, PE Keller - *US Patent* 5,680,866, 1997
- [16] "Electronic noses and disease diagnostics" Anthony P.F. Turner & Naresh Magan ,*Nature Reviews Microbiology* 2,161-166(February 2004)
- [17] "Neural networks in business: a survey of applications " (1992–1998)A Vellido, PJG Lisboa, J Vaughan - *Expert Systems with applications*, 1999 – Elsevier.
- [18] "Behavioral personal digital assistants: The seventh generation of computing" KR Stephens, WR Hutchison - *The Analysis of verbal behavior*, 1992
- [19] Imran Shafi, Jamil Ahmad, Syed Ismail Shah, Faisal M Kashif. "Impact of Varying Neurons and Hidden Layers in Neural Network Architecture for a Time Frequency Application" , 2006 IEEE International Multitopic Conference, 2006
- [20] N. Kannathal. "Classification of Cardiac Patient States Using Artificial Neural Networks" , *Advances in Cardiac Signal Processing*, 2007

Citation: Patil, S. et al. (2018). *Comprehensive Study & Overview of Neural Networks for Classification of Diseases. International Journal of Innovative Research in Electronics and Communications (IJIREC)*, 5(3), pp.19-27. <http://dx.doi.org/10.20431/2349-4050.0503003>

Copyright: © 2018 Bazil Taha Ahmed, This is an open-access article distributed under the terms of the Creative Commons Attribution License, which permits unrestricted use, distribution, and reproduction in any medium, provided the original author and source are credited.