

Coherent Access and Its Methods in Communication Engineering

Shashikant Patil¹, Kaushal Hissaria², Vanshika Agrawal³, Sanchiti Arora⁴

SVKMs NMIMS Shirpur Campus, India

Abstract: *In this paper we have addressed and reviewed the useful aspects of coherent access and its uses in the future of optical access networks. The scarcity of optical spectrum, the required flexibility, the effectiveness of coherent technique towards the future passive optical networks (PON) are important perspectives of the study carried out. The combination of techniques of coherent access is observed and interpreted. These are- Digital Signal processing, Nyquist Pulse shaping and coherent detection are described as key enablers of the future optical access networks. Also a method for coherent access such as by using Inferno meter is taken into account. Also a method of Coherent reception is discussed*

Keywords: *Access networks, optical coherent detection, DSP, Nyquist Pulse shaping*

1. INTRODUCTION

Future Optical Access Networks (FOAN) are having privilege of taking full advantages of recent advancements made in the field of optics and optical communications. Cost and data rate will stay the main aspects but the factors such as sustainability reliability and flexibility will be counted as enablers for challenges that lie ahead for the operators in the field.

Optical access standard have evolved largely within last two decades with a lavish speed. Mainly IEEE802.3 and ITU-T have played an important key role in the advancement of optical access in communication engineering.

First PON standards such as BPON (Broadband Passive Optical Network), GPON (Gigabit Passive Optical Network) and EPON (Ethernet PON) rely on the specifications of the component where the upstream (US) and downstream (DS) signals are allocated with bands greater than 10nm, so that the laser and filter tolerances are high and the production cost and the yields are low [2][1].

A recent study shows that that the industry and the standards have understood the evolution that the components and production cycles have gone through. A great pattern change was included in NGPON-2 standards. DWDM has appeared to a path for balanced cost and flexibility.

Due to versatility of end user types and highly time varying traffic demands of mobile networks, the F-OAN's design tend to shift from regular static to dynamic and flexible. In addition, the increasing network capacity should be continuous enough to ease the use of legacy network infrastructure to the highest degree possible and assure network growth feasibly and economically.

In fig-1a. A block diagram of network is shown, where many system are connected in hybrid optical distribution network (ODN). In the next figure-fig1b. Current spectral location is shown. It needs attention in FOAN's as most of low bands of the fibre are exploited coherent technology in conjunction with laser sources can help in solving the issue in a versatile and easy way.

2. COHERENT DETECTION IN ACCESS NETWORKS

According to fresh studies, PON is supported by intensity modulation of light. For short reach and effort has been pit into multi-level to save the electrical bandwidth data rate from increasing. According to the above idea it is possible to consider the advantages of combining optical phase with multi symbol formats allowing great increase in the data rate and avoiding putting pressure on the electrical side and as a result it lowers the cost. Achieving the above mentioned can be easy with coherent detection.

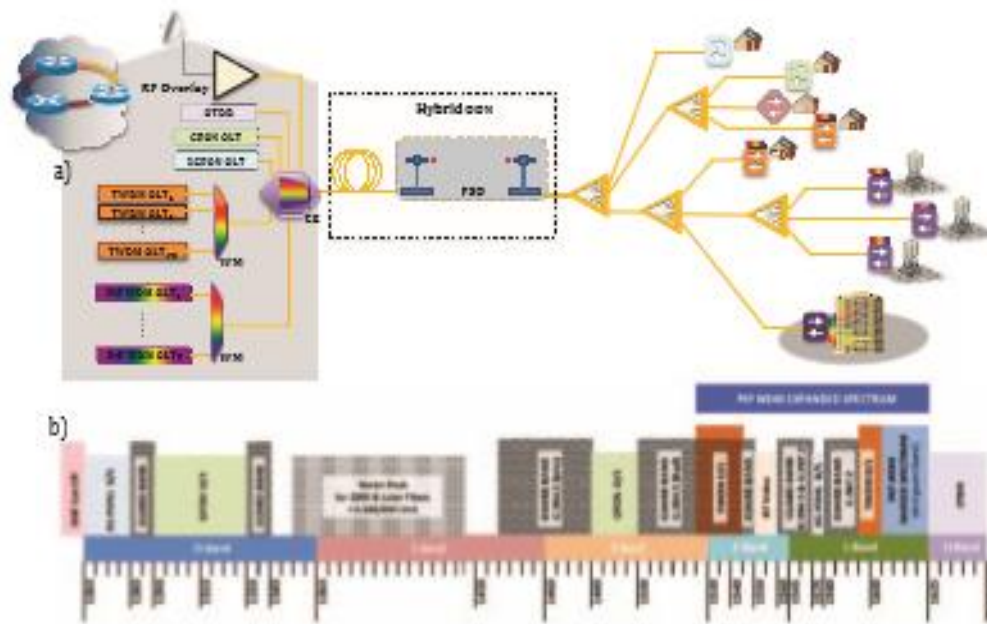

Fig1. Wavelength plan representation for multiple system configurations of F-OANs. The inset shows a flexible wavelength grid of UDWDM-PON system supporting a bidirectional transmission with unbalanced optical power per US channels.[3][4]

The data rate being low is the main limitation that kept coherent technology on hold in the past years, which also resulted in complex control of high quality lasers. On the other hand of coherent detection lies Digital Signal processing (DSP).It allows flexibility which is based on computational resources, which used to be difficult and expensive but now available at good pricing [9]. The problem faced by DSP approach is conversion of Analog to Digital domain, which is still a problem if we taking sampling frequency above 5Ga/s. Many research groups have widely reported the advantages provided by coherent reception for F-OAN. Because of good ability to improve the receiver sensitivity and selectivity of its wavelength, the ODN can be easily extended with an improvement in the end-user in the system with delicate WDM channels.

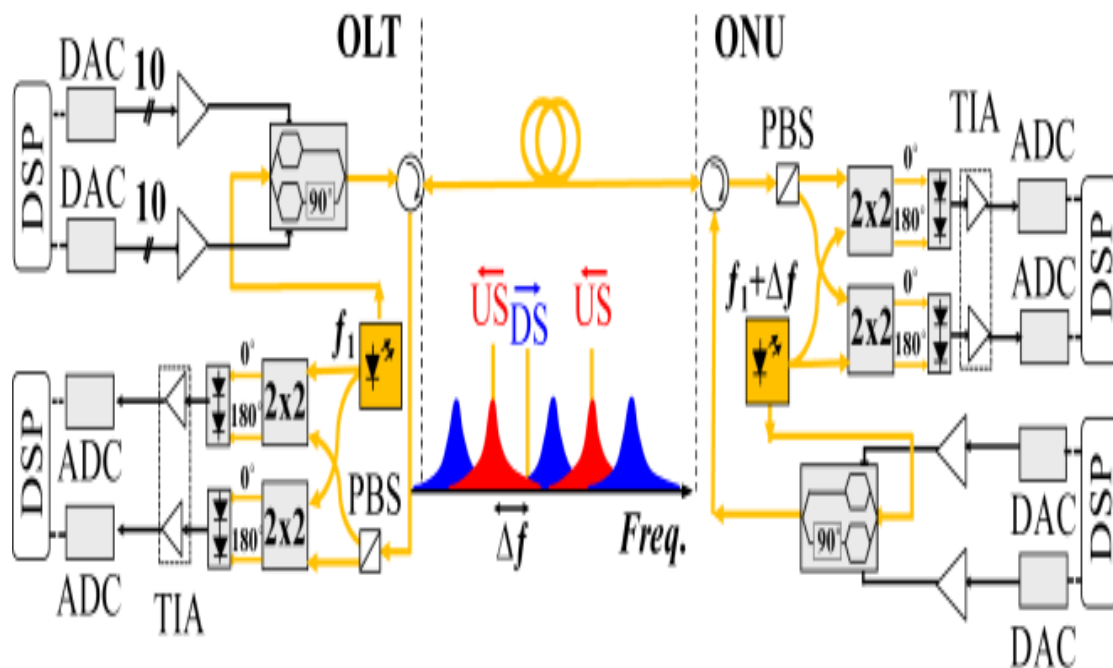

Fig2. Schematic diagrams of a simple coherent PON system based on high bandwidth DAC/ADCs at the OLT using a single laser and modulator for 10 UDWDM channels. The ONU side is based on coherent heterodyne detection using a polarization diversity receiver. ONU- optical network unit, OLT- optical line terminal, DAC/ADC- digital-to-analog and the analog-to-digital converter, DSP- digital signal processing, PBS- polarization beam splitter; LPF- low-pass filter, TIA- transimpedance amplifier.[4][2]

Several projects like COCONUT have been suggested with new transmission strategies with a mixing concept like OOK (On-Off keying) modulation concept and schemes for simplified receiver, in order to simplify transmitter and receiver architecture for optical line transmission (OLT) and Optical Network Unit (ONU).

In Fig2. A typical coherent PON architecture operation in both transmitter and receiver is shown. It is just a matter of signal processing that flexibly address of limitation of PON. Another process, Nyquist Pulse Shaping has also been proposed in a way to deliver data rate of 10GB/s and also a very high spectral occupation. Fig 3 shows an example of downstream (DS) which is tightly multiplexed with upstream (US). Nyquist pulse shaping brings extra complexion for OLT and ONU transmitters, because of required number of filter taps for signal shaping. Also the peak to peak average ration of the signal increases when the roll-off factor tends to zero, which forces to select DAC/ADC's with higher effective number of bits.

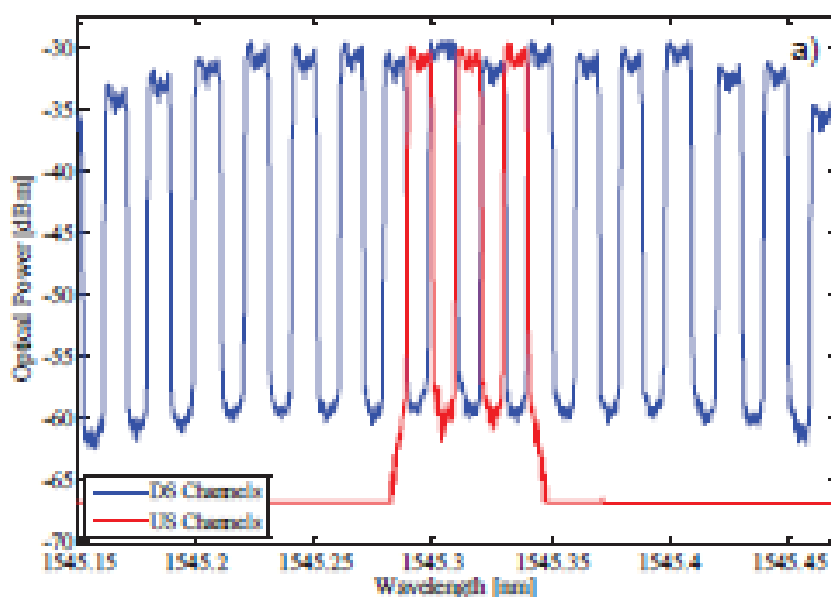

Fig3. (a) UDWDM channels interleaving US and DS in the optical domain for almost full spectral usage for minimal backscattering [3]

It has also been demonstrated that this technique will ease Rayleigh Back scattering, cross talk and four wave mixing. Also single side band modulation can be easily implemented using frequency shifting from carrier of both upstream (US) and downstream (DS) which results in full bandwidth allocation and simplified operations. FOAN's also require a simplified DSP design to be compatible with feasible transceivers solutions with efficient power consumption.

The following figure fig4. Shows a simple DSP based OAN for US and DS direction. Frequency or phase cycle-slips (CS) which is a phenomena caused by phase discontinuities must be taken a note of recently a demonstration of field-trial operation of a bidirectional Nyquist coherent PON system with real time OLT and ONU's, using off the shelf real time FPGA transceiver was shown. The result observed was as same as that depicted in fig 2a. , high spectral density can be achieved due to coherent detection and its properties as low power per channel is required and some compensation is achieved due to DSP.[10]For low RF frequencies (up to 250 MHz) there is more than 10dB reduction in power spectral density. When compared with 1.25 Gbaud NRZ and Nyquist QPSK.

3. COHERENT FIBRE-OPTIC CODE DIVISION MULTIPLE ACCESS RECEIVER USING AN INTERFEROMETER

Spread spectrum code division multiple access method has been studied for fibre optic local area network as by CDMA one can access several transmitter or receiver over a single channel simultaneously so delay is aided and fibre optic has wide band width. In coherent optical CDMA the basic network and envelope pattern for impulse responses is same as incoherent optical CDMA but the phases of pulse sequence are important as the pulses are summed up coherently.

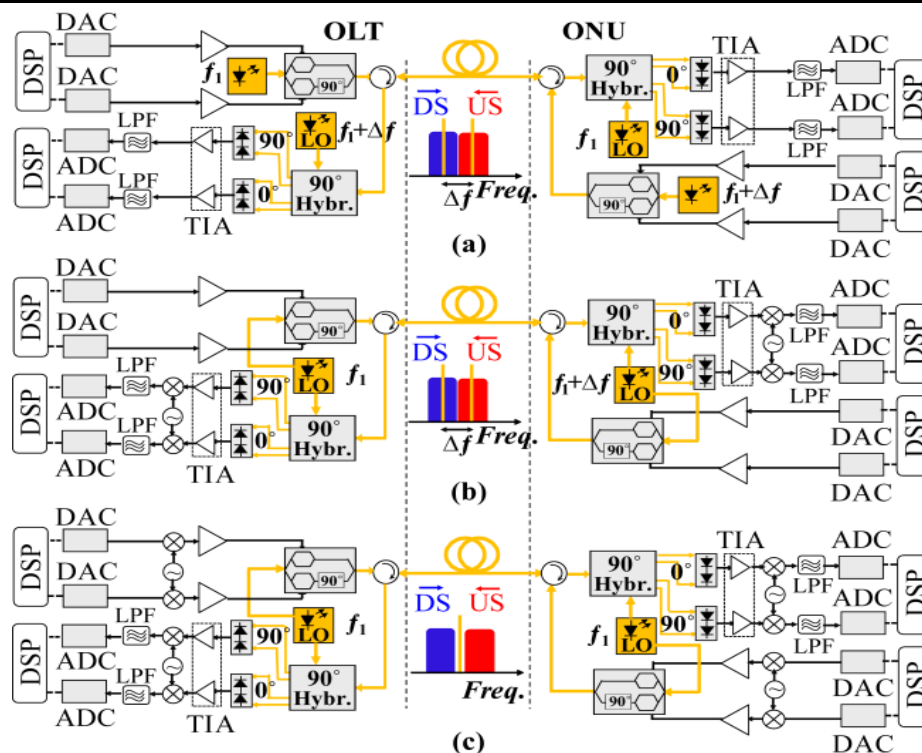

Fig4. Schematic diagrams of coherent PON system based on low bandwidth DAC/ADCs at the OLT and ONU (a) using two different lasers for the transmitter and receiver, or (b) using heterodyne detection with only a laser for the transmitter and receiver, or finally (c) using a heterodyne generation and detection approach with only a laser for the transmitter and receiver. In (b) and (c), the conversion to baseband can be carried out by RF devices such as mixers and analog filters, or in the digital domain after higher bandwidth ADCs without the need for RF devices. [4]

In a typical fibre optic CDMA communication received signal sequence is correlates with the stored address in decoder. Coherent CDMA has potential advantages from the point of view of power budget, side lobes, and signal-to-noise ratio[6]. When we try to implement the coherent optical CDMA, some practical difficulties occur due to environmental influence. A novel receiver system is proposed, the conventional incoherent matched filter followed by post signal processing block, signal processing is performed coherently.

The complexity and BER performance of the proposed receiver lie between incoherent and coherent CDMA networks. This could be a simple and suitable method of obtaining the acceptable performance using practical devices.[6]

4. IMPACT AND COMPENSATION TECHNIQUES OF LASER PHASE NOISE IN ULTRA-DENSE COHERENT ACCESS NETWORKS

Coherent reception is the most advanced reception method that allows digital equalization of transmission impairments, such as chromatic dispersion (CD), polarization mode dispersion (PMD), phase noise (PN) and nonlinear effects. This is the most promising solution for the future generation optical system due to its several advantages over already installed detection system.

Performance comparison between two carrier phase recovery (CPR) algorithms used to mitigate the impact of the laser phase noise in an ultra-dense wavelength-division multiplexing passive optical network WDM-PON (UDWDM-PON) scenario as shown in fig5. The demodulation of coherent optical signals can be possible by use of an optical or electrical phase locked loop (PLL) to synchronize the frequency and the phase of the local oscillator with the transmitter laser[7].However, optical receivers based on OPLL (Optical Phase Locked Loop) suffer from implementation difficulties and stringent laser line width requirements, especially when scalability to higher-order optical modulation formats is desired.

The line widths of the optical network unit (ONU) and optical line terminal (OLT) lasers play an important role in the system performance, fine laser line widths of $\Delta\nu.Ts = 3 \times 10^{-4}$ are required in order to obtain low penalties.[7]

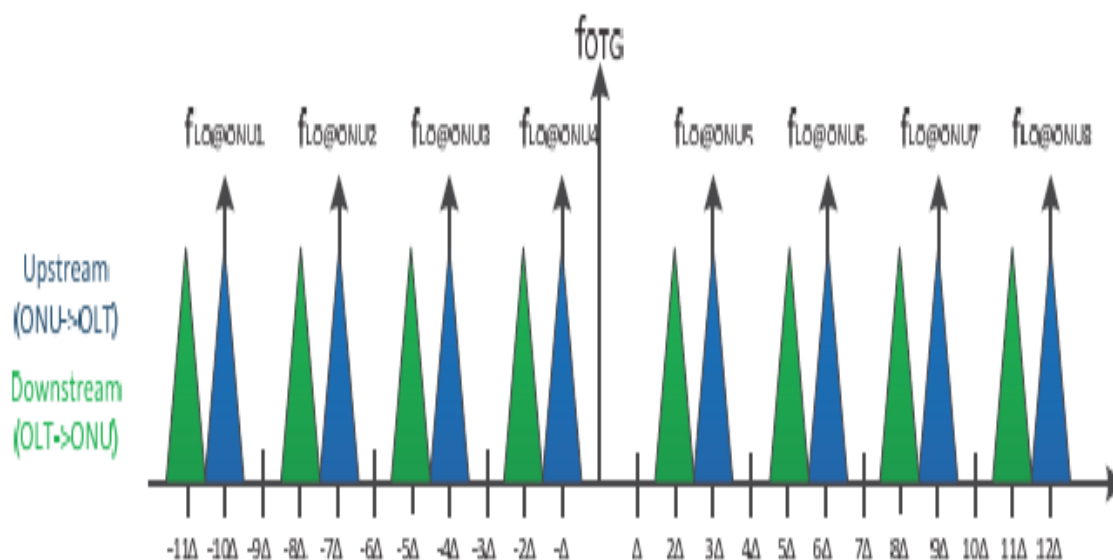

Fig5. Wavelength plan.[7]

5. INP-BASED TRANSISTORS FOR FUTURE FULLY COHERENT ACCESS NETWORK

Transparent and direct conversion between optical fiber and sub-THz wave wireless communication networks is needed for Next-gen ultra-broadband ubiquitous, resilient access network systems in order to keep the highest data transmission throughout. Media-independent access network systems is realized by the convergence between the optical fiber (wired) and the sub-THz wireless transmissions with coherency. The key device to realize the fully coherent transmission is an ultra-broadband, high speed carrier convertor.

We investigate the conversion of an optically wired data stream to a sub-THz wireless data and eventually from the wireless sub-THz to an IF band. We examine such functionalities of the photonic frequency down conversions in field Effect transistors (FETs). We introduce and compare a graphene-channel FET (G-FET) and an InP-based high electron mobility transistor (InP-HEMT) to perform the photonic double-mixing conversion over the optical frequency bands to the microwave IF bands via sub-THz wireless frequency bands [5].

Experimental results indicate the potentiality of these transistors over the sub-THz wireless frequency bands when the device feature size is scaled down to the level of sub-100 nm.

Feasibility of the G-FET as a photonic frequency double-mixing conversion device for future fully coherent access network systems was examined in comparison with the InP-based HEMT. Single G-FET can photo mix the optical subcarriers to

Generate **LO** and mix down the **RF** data on the sub-THz carrier to the **IF** band simultaneously.

An improved high-speed and high sensitive G-FET by scaling down the feature size To the level of sub-100 nm range will perform an excellent frequency conversion. [5]

6. CONCLUSION

We have addressed and analysed the latest trends of coherent access in communication engineering and interpreted various. The scarcity of spectrum, the required flexibility and constant evolution of PON are the important aspects of this study and also the use of coherent techniques in optical fibre communication or access. Its filter-less receiver operation, the inherent gain and its flexibility with regard to signal manipulation i.e. higher order formats, pulse shaping, compensation mechanisms, etc. allow taking advantage of the full potential of the fibre transmission in a flexible way. Also we addressed coherent access using inferno meter and InP based transistors for future purposes. This study and its findings are useful for future networks and advanced communications.

REFERENCES

- [1] IEEE P802.3av task force, www.ieee802.org/3/av/.
- [2] ITU-T recommendation: www.itu.int/rec/T-REC-G.989.2.
- [3] Coherent Access-A.texeira, A.Shahpari, R.ferreira
- [4] Coherent Access:A Review-Ruben S.Luis, F.Guiomar
- [5] Sub-THz Photonic Frequency Conversion Using Graphene andInP-Based Transistors for Future Fully Coherent Access Network- Kenta Sugawara, Taiichi Otsuji
- [6] Coherent Fibre-optic code division multiple access receiver using an interferometer- Hyung-Ook Jang and Je-Myung Jeong
- [7] Impact and Compensation Techniques of Laser Phase Noise inUltra-Dense Coherent Access Networks- André Silva, Miguel Drummond
- [8] COHERENT OPTICAL COMMUNICATION-G. Heydt
- [9] R. Ferreira “Demonstration of Nyquist UDWDM-PON with digital signal processing in real-time,” OFC 2015, paper Th3I.4.
- [10] A. Shahpari et al. “Terabit+ (192×10Gb/s) Nyquist shaped UDWDM coherent PON with upstream and downstream over a 12.8 nm band,” OFC 2013, paper PDP5B3.

AUTHORS' BIOGRAPHY



Professor Shashikant Patil is a prominent educationist and Teacher. Presently he is working as an Associate Professor with SVKMs NMIMS. He is also serving as an Associate Editor, Editorial Board Member, Technical Advisory Board Member, Potential Peer Reviewer and Journal Referee on at least 50 Journals. He is also having an association with Elsevier Editorial Series, Taylor and Francis, Springer Link Journals as a potential peer reviewer and journal referee. He is also associated with IEEE, ACM, CSI, ISTE, NHRDN, E4C and IETE as Professional member and nominated as an affiliate member on various committees of IEEE Signal Processing Society (SPS) and IEEE Communications Society (ComSoc). He is a recipient of Best Researcher Award 2014 of SVKMs NMIMS Shirpur. Recently he has been chosen to serve as a Member Executive Committee Member & Joint Secretary on IEEE CSI India Council as well as core team member of the Social Media and Online Content management team, Visibility Committee of IEEE SPS at an international Level. He has published approximately 36 articles in various conferences and journals at national and international level. In IEEE he is playing a key role as Regional Lead Ambassador for Region 10 for IEEE Day 2015 and 2016 events. He is member IEEE RFID Technical Council and SIG Member of IOT. His research interests are signal processing and imaging. He also serves as an Associate Editor on IEEE RFID and IEEE Software Defined Networks (SDN) Journal. Additionally he is shouldering a responsibility of EiC of IEEE CRFID Newsletter.



Kaushal Hissaria, is a 3rd year student currently pursuing B.Tech from NMIMS MPSTME in the field of Elec. And Telecommunication. His field of interests include Optical Fibre Communication and Signal Processing.



Sanchiti Arora, is a student currently in 3rd year of her B.Tech in Electronics and Telecommunication from NMIMS MPSTME. She has an interest in the field of Communication systems and Computer Networks.



Vanshika Agrawal, is a 3rd year student of B.Tech Electronics and Telecommunication from NMIMS MPSTME. Her interests are in Communication systems, Image Processing and Electrical Networks.