

Microcontroller Based PCR Thermal Cycler for DNA Amplification

Sidhant Sanjay Kulkarni

Asst. Prof., E&Tc Dept
SRES COE, Kopargaon
sidhantkulkarni@gmail.com

Ananta Suresh Chavan

Asst.Prof., E&Tc Dept
SRES COE, Kopargaon
anantachavan42@gmail.com

Abstract: Polymerase Chain Reaction is a common molecular biology technique for amplifying a specific sequence of De-oxyribose nuclid acid molecule for sequencing or detection purposes. PCR is a cyclical reaction in which the number of DNA molecules of interest is doubled with each repeat of the reaction.

Keywords: DNA, Polymerase, PCR, temparature Cycles

1. INTRODUCTION

PCR (polymerase chain reaction) is a method to analyze a short sequence of DNA (or RNA) even in samples containing only minute quantities of DNA or RNA. PCR is used to reproduce (amplify) selected sections of DNA or RNA. Previously, amplification of DNA involved cloning the segments of interest into vectors for expression in bacteria, and took weeks. But now, with PCR done in test tubes, it takes only a few hours. PCR is highly efficient so that untold numbers of copies can be made of the DNA.

Almost all PCR applications employ a heat-stable DNA polymerase, such as Taq polymerase, an enzyme originally isolated from the bacterium *Thermus aquaticus*. This DNA polymerase enzymatically assembles a new DNA strand from DNA building blocks, the nucleotides, by using single-stranded DNA as a template and DNA oligonucleotides (also called DNA primers), which are required for initiation of DNA synthesis. The vast majority of PCR methods use thermal cycling, i.e., alternately heating and cooling the PCR sample to a defined series of temperature steps. These thermal cycling steps are necessary first to physically separate the two strands in a DNA double helix at a high temperature in a process called DNA melting. At a lower temperature, each strand is then used as the template in DNA synthesis by the DNA polymerase to selectively amplify the target DNA. The selectivity of PCR results from the use of primers that are complementary to the DNA region targeted for amplification under specific thermal cycling conditions.

There are three major steps involved in a PCR as shown in Fig.1 for amplification of DNA. These three steps are repeated for 30 or 40 cycles. The cycles are done on an automated cycler.

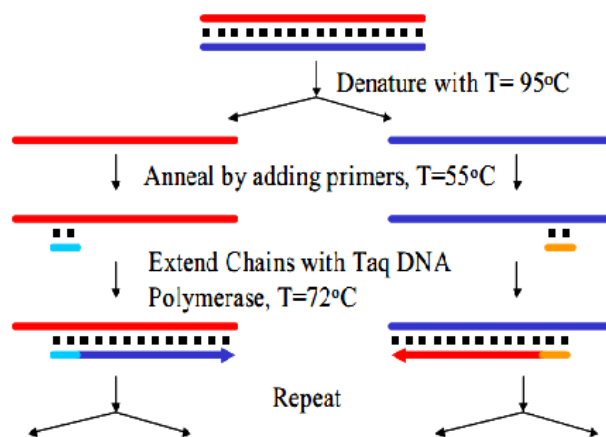

Fig. 1. Steps involved in amplification of DNA by PCR.

Thermal Cycler is a device which rapidly heats and cools the test tubes containing the reaction mixture. As shown in Table I each step like initial denaturation (alteration of structure) for 1 to 4 min, annealing (joining) for 1 to 1.5 min, and extension takes place at a different temperature depending on DNA. And the process is repeated for number of cycles to produce multiple copies of same DNA structure. Once the cycles are over the reaction mixture undergoes a last step of final elongation for 5 to 6 min.

The procedure for performing PCR consists of first preparing the reagents and then adding them to a DNA sample in a sample block of usually 60 to 96 vials (In our case 8 vials) of 0.2mL to 0.5mL volume each as The thermal cycler cycles the block temperature using heating and cooling air-flow as per the requirement as indicated in Table 1[3][4].

Table 1. PCR Thermal Cycling Program

Cycle Description	Temperature	Time (min)
Initial Denaturation	95°C	1-4
Denaturation	95°C	0.5 to 1
Annealing	50 to 65°C	1 to 1.5
Extension	72°C	0.75 to 3
Final elongation	72 °C	5

2. SYSTEM DESIGN

2.1 Block Diagram

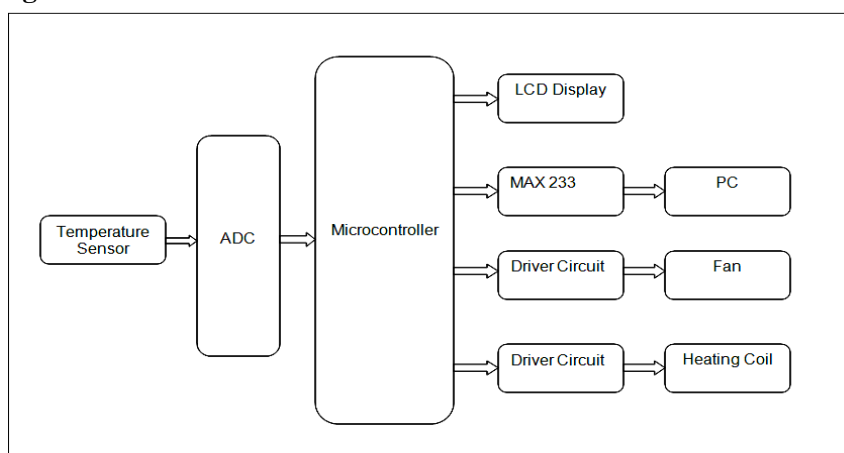

Fig. 2. Block Diagram of Low cost PCR Thermal Cycler

In our system, the process will have a closed loop intelligent system that will continuously monitor the temperature of copper block which contains the reaction mixture. The current parameter readings are shown on a display module. The moment any parameter crosses the set point opto-coupler is energized to take control of the process.

A block diagram of the various parts of the cycler is shown in Fig. 2. It consists of Micro controller 89C51 to control entire process of cycler. The heater coil for heating the reaction mixture and a AC fan for cooling the reaction tubes its driver circuit composed of optocoupler IC MOC3011, A temperature sensor LM 35A is used to sense the temperature of copper block and the output of the sensor is given to ADC and The output from ADC is directly fed to the micro-controller to constitute the on–off electronic control. The cycling parameters are entered into the micro-controller through the computer through Visual Basics and can be monitored on the display during cycling. When the temperature of the tube exceeds the set-point, micro-controller switches off the heating and turns ON the Fan circuit and vice versa..A micro-controller with LCD display is implemented to display sensing parameter continuously. For programming the cycling parameters A Graphical user interface (GUI) has also been developed on PC.

3. EQUATIONS

3.1 Fan Design (CFM Calculations)

Cooling was carried out by blowing air from AC powered from a 220 V ac source, and controlled by a Optocoupler.

The science of heat transfer provides the basis for cooling system design. The basic formula of heat transfer is written as:

$$Q = m \times \Delta T \times C_p \dots \dots \dots (1)$$

Where: q = heat transferred
 m = mass
 ΔT = difference in temperature
 C_p = specific heat

A fundamental implication of the above formula is that the amount of heat that can be transferred from one thing to another is directly proportional to the difference in temperature between the two things (ΔT). The heat transfer formula from above can be re-written to apply directly to a cooling fan as,

$$cfmr = Q / \Delta T \dots \dots \dots (2)$$

Where:
 $cfmr$ = the required airflow generated by the cooling fan
 Q = the required amount of heat rejected into the air to maintain proper temperature.
 ΔT = temperature difference

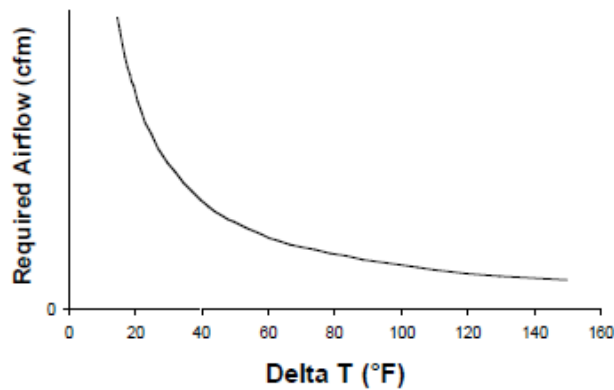

Fig. 3. Relationship between CFM and Temp. difference

IN PCR it consist of various temperature cycles in which either energy is needed to supplied when we want to increase the temperature and particular amount of energy needed to be removed when temperature need to be reduced.

In our case,

Table 2. Energy and CFM Calculations for Fan

Temperature difference	energy to be released	CFM needed
95-72 °C	2849Joules	77
72 to RT	4004Joules	77

Therefore we require AC fan with CFM rating equal to 77

we have selected the AC fan with standard CFM rating of 115 (Model FP108-7).

3.2 Heater Design (Energy calculations for Heater)

The amount of heat actually transferred from copper block to polypropylene by conduction when there is temperature difference between two bodies is calculated by the formula,

Heat conducted through several walls in good thermal contact can be expressed as

$$q = (T_1 - T_n) / ((s_1/k_1A) + (s_2/k_2A) + \dots (s_n/k_nA)) (3)$$

where

q =conductive heat transfer

T1=temperature of copper block

Tn=temperature of polypropylene

S1=thickness of copper

S2=thickness of polypropylene

K1=thermal conductivity of copper

K2=thermal conductivity of polypropylene

A1=heat transfer area of copper

A2=heat transfer area of polypropylene.

Surface Area in contact of polypropylene tube =

Total surface area of cone + total surface area of upper cylinder

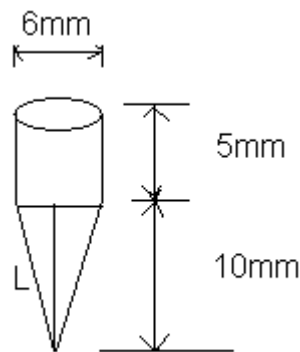

Fig. 4. Dimensional structure of Polypropylene tube

$$\text{Surface area of cone} = \pi r^2 + \pi r l \dots \dots \dots (4)$$

Where, r is radius of cone

l is slant height

$$\begin{aligned} &= \pi r (r+l) \\ &= \pi \times 3\text{mm} (13.44\text{mm}) \\ &= 126.66 \text{ mm}^2 \end{aligned}$$

Therefore, total surface area of cone in contact = 126.66mm²

$$\text{Surface area of cylinder} = 2\pi r^2 + 2\pi rh \dots \dots \dots (5)$$

Where, h =height of cylinder

r =radius of cylinder

$$\begin{aligned} &= 2\pi r (r+h) \\ &= 2\pi \times 3\text{mm} (3\text{mm}+5\text{mm}) \\ &= 150.79\text{mm}^2 \end{aligned}$$

Therefore, total surface area of cylinder in contact = 150.79mm²

Therefore,

$$\begin{aligned} \text{Total surface area in contact with copper block} &= 126.66+150.79 \\ &= 277.45\text{mm}^2 \end{aligned}$$

Therefore,

The conductive heat transfer through the copper wall can be calculated by equation (1)

by experiments it is observed that maximum temperature difference between copper and polypropylene is 15°C. so taking T1-Tn=15°C

Microcontroller Based PCR Thermal Cycler for DNA Amplification

$$q = \frac{15 / (1 \times 10^{-3})}{(0.22 \times 277.45 \times 10^{-6}) + (2 \times 10^{-3}) / (393 \times 277.45 \times 10^{-6})}$$

$$q = 0.9146 \text{ watt/m}^2$$

This is the amount of heat actually transferred from copper block to polypropylene by conduction when the temperature difference is 15°C, which is very negligible as compared with energy consumed by copper block. Therefore, we assume that energy supplied by the heater is entirely used for raising the temperature of reaction mixture and no heat loss takes place in copper block and polypropylene tubes.

According to the formulas of heat transfer,

$$\text{Energy} = \text{Mass} \times \text{Specific Heat} \times \text{Temp. Difference} \dots\dots\dots(4)$$

And,

$$\text{Power} = \text{Energy} / \text{Time} \dots\dots\dots(5)$$

Putting specific heat of copper = 0.385 J/g°C

mass of copper block carrying vials = 200 gm

temperature difference = (95°C - RT) and assuming

required heating rate = 1°C we get

Wattage of heater required to raise the temperature of DNA sample from RT to 95°C is 77 watts.

4. FIGURES AND TABLES

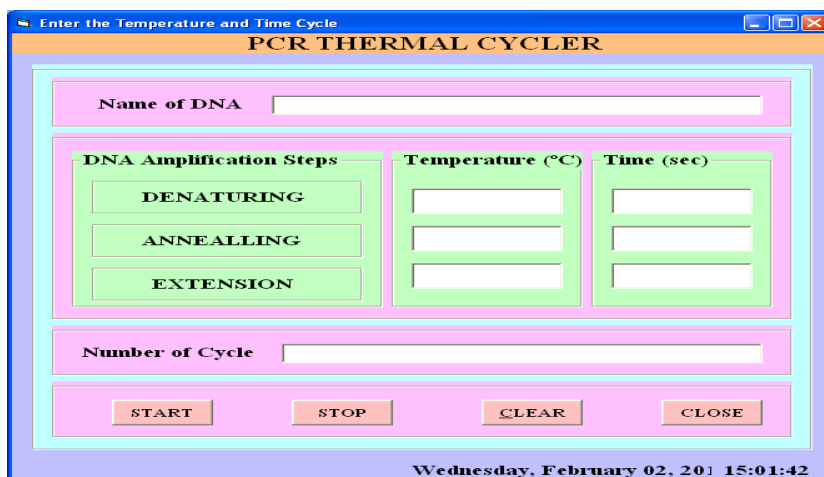

Fig. 5. Data Entry Form of GUI

Table 3. Output for 10 subsequent trial runs

Step Name (DNA)	Temperature Rise /fall	Time required for heating /cooling	Heating / Cooling rate
Annelaing	RT to 95 °C	65 to 70 sec	1 °C/s
denaturation	95 to 54 °C	150 to 160sec	0.25 °C/s
Extension	54 to 72 °C	25 to 28 sec	1 °C/s

5. CONCLUSION

In order to carry out DNA amplification by using the prototype module of PCR thermal cycler and to carry out different heating and cooling cycles we have developed a low cost model using simple nichrome coil heater and air forced convection technique by blowing the air at the specimen by using a AC fan with required CFM and air blowing capability. We have Developed user friendly GUI by using Visual Basics to enter different temperature profiles of DNA to be amplified and to observe the current temperature of the system.

REFERENCES

[1]. P. Denton and H. Reisner, in PCR Protocols: A Guide to Method and Applications, edited by M. Innis et al. (Academic, New York, 1990), Chap. 52.

- [2]. C. T. Wittver, G. B. Reed, K. M. Ririe, "The Polymerase Chain Reaction", pp. 174-181, Birkhauser, Boston, MA, 1994.
- [3]. D.S. Yoon, Y.S. Lee, Y. Lee, H.J. Cho, S.W. Sung, K.W. Oh, J. Cha, G. Lim, Precise temperature control and rapid thermal cycling in a micromachined DNA polymerase chain reaction chip, *J. Micromech. Microeng.* 12 (2002) 813–823.
- [4]. D.S. Lee, C.Y. Tsai, W.H. Yuan, P.J. Chen, P.H. Chen, A new thermal cycling mechanism for effective polymerase chain reaction in microliter volumes, *Microsyst. Technol.* 10 (2004) 579–584.
- [5]. P. K. Upadhyay, D. V. Gadre, "A personal-computer-based thermocycler for polymerase chain reaction", *Meas. Sci. Technol.*, 6, pp. 588-592, 1995.
- [6]. Debjani Pala and V. Venkataraman, K. Naga Mohan and H. Sharat Chandra, Vasant Natarajan, A power-efficient thermocycler based on induction heating for DNA amplification by polymerase chain reaction.
- [7]. C. T. Wittver, G. C. Fillmore, D. R. Hillyard, "Automated Polymerase Chain Reaction in Capillary Tubes with Hot Air", *Nucleic Acids Research*, Vol. 17, No. 11, pp. 4353-4357, 1989.
- [8]. D.S. Lee, C.Y. Tsai, W.H. Yuan, P.J. Chen, P.H. Chen, A new thermal cycling mechanism for effective polymerase chain reaction in microliter volumes, *Microsyst. Technol.* 10 (2004) 579–584..
- [9]. The PTC-0150 minicycler operations manual, version 4.0, MJ Research, USA.
- [10]. C. F. Chou, R. Changrani, P. Roberts, Daniel James Sadler, J. Burdon, F. Zenhausern, S. Lin, A. Mulholland, N. Swami, R. Terbrueggen, "A minitiated cyclic PCR device – modeling and experiments", *Microelectronic Engineering*, 61-62, pp. 921-925, 2002.
- [11]. Sidhant Sanjay Kulkarni, "Microcontroller based Low cost PCR Thermal Cycler for DNA Amplification", *IJERT* ISSN: 2278-0181, Vol. 2 Issue 11, November – 2013.

AUTHORS' BIOGRAPHY



Sidhant Sanjay Kulkarni, Currently working as an Assistant Professor in SRES COE, Kopergaon, Pune University, Maharashtra

M.Tech: DOEACC, Aurangabad

B.E.: Dr.BAMU, Aurangabad (Distinction)

Experience: 3.5 year teaching.

Field of interest: Communication, VLSI Design, Biomedical instrumentation



Ananta Suresh Chavan, Currently working as an Assistant Professor in SRES COE, Kopergaon, Pune University, Maharashtra

B.Tech: COEP (2012)

B.E.: Pune University (Distinction)

GATE qualified two times.

Experience: 1 year industry, 2 years teaching.

Field of interest: Communication, VLSI Design, Biomedical instrumentation