

Wireless Energy Meter Using Handheld Reader

Sunkari Umarani¹, N.Hathiram²

¹PG Scholar, Electronics and Communication Engineering,
Vignan Institute of technology and science, Telangana, India
sunkari.umarani@gmail.com

²Assistant Professor, Electronics and Communication Engineering,
Vignan Institute of technology and science, Telangana, India

Abstract: *The paper proposes an innovative design to develop a system based on Embedded micro controller that is used for monitoring the voltage and current of a certain load in a home, industries or substations. By analysing the values we can design a perfect models to protect the system from the rise in mentioned parameters. Here the system measures the Voltage and current values of a load with the help of Current transformer (current sensor) and potential transformer.the measured values will be displayed on LCD, and we can also log the details in to the Personal computer wirelesly using Zigbee protocol.The ultimate objective is to monitor the electrical parameters continuously and hence to guard the burning of loads due to the constraints such as overload and input high voltage. If any of these values increases beyond the limit then the system gives the alert and entire unit is shut down by the designed controlling unit.*

Keywords: *Electricity, Power Transmission systems, Substations, Distribution Transformers, Generators, Microcontrollers.*

1. INTRODUCTION

Electricity is an extremely handy and useful form of energy. It plays an ever growing role in our modern industrialized society. The electrical power systems are highly non linear, extremely huge and complex networks. Such electric power systems are unified for economical benefits, increased reliability and operational advantages. They are one of the most significant elements of both national and global infrastructure, and when these systems collapse it leads to major direct and indirect impacts on the economy and national security. A power system consists of components such as generators, lines, transformers, loads, switches and compensators. However, a widely dispersed power sources and loads are the general configuration of modern power systems Electric power systems can be divided into two sub-systems, namely, transmission systems and distribution systems.

The main process of a transmission system is to transfer electric power from electric generators to customer area whereas a distribution system provides an ultimate link between high voltage transmission systems and consumer services. In other words, the power is distributed to different customers from the distribution system through feeders, distributors and service mains. Supplying electricity to consumers necessitates power generation, transmission, and distribution. Initially electric power is generated by using electric generators such as:

nuclear power generators, thermal power generators and hydraulic power generators and then transmitted through transmission systems using high voltage. Power departs from the generator and enters into a transmission substation, where huge transformers convert the generator's voltage to extremely high volt ages (155kV to 765 kV) for long -distance (up to about 300 miles) transmission. Then, the voltage level is reduced using transformers and power is transferred to customers through electric power distribution systems. Power starts from the transmission grid at distribution substations where the voltage is stepped - down (typically to less than 10kV) and

carried by smaller distribution lines to supply commercial, residential, and industrial users. Novel electric power systems encompassing of power transmission and distribution grids consist of copious number of distributed, autonomously managed, capital – intensive assets. Such assets comprise: 1.) power plants, 2.) transmission lines, 3.) transformers, and 4.) protection equipment.

Generally the maintenance of a transformer is one of the biggest problems in the Electricity Board (EB). During strange events for some reasons the transformer is burned out due to the over load and short circuit in their winding. Also the oil temperature is increased due to the increase in the level of current flowing through their internal windings. This results in an unexpected raise in voltage, current or temperature in the distribution transformer. Therefore, we are proposing the automation of the Load/ transformer from the EB substation. In the automation, we consider the voltage, current as the parameters to be monitored. Hence, we design an automation system based on microcontroller which continuously monitors the transformer/Load. Because of the microcontroller operation, the transformer present in the substation which is turned off in the main station.

2. PROPOSED MICROCONTROLLER BASED INDUSTRIAL PARAMETER MONITORING SYSTEM

This section gives the overview of the monitoring and controlling scheme of industrial parameters. A general block diagram of the proposed scheme is given in Figure. 1 General Block Diagram of Monitoring and Controlling Scheme The whole system is divided into two parts- Load section and monitoring section. In the load section a network of sensor and transducers are used to monitor the risky parameters such as voltage, current of load/transformer at the test location .The monitoring data is simultaneously fed to the micro-controller. This data is transmitted efficiently and smoothly to receiver end through wireless Zigbee Communication Protocol (IEEE802.15.4 Standards). The micro-controller at the transmitter end is so programmed that if the monitoring parameters come out of the desired or safety limit, a signal will be generated by the micro-controller which will energize the relay circuit and the contractor cuts the mains supply to the load. The data received at the receiver end is transferred to computer system through MAX232 interface. Thus a continuous monitoring of the parameters of load/transformer can be done from a remote location far away from the actual working location. If the user anytime wants to

Start or stop the load/transformer, a signal will be given by the computer system present at the monitoring end, which is communicated at the transmitter end through Zigbee protocol. In turn the micro-controller unit present at plant location, generates a signal which energizes and de-energizes the relay circuitry to stop and start the load/transformer respectively. Thus this system not only monitors the operation of load/transformer but also protects it from the severe faults that commonly occur.

3. BLOCK DIAGRAM

3.1. Sensor and Transducer Unit

This unit consists of several sensors and transducers used to detect the predetermined parameters of the induction machine. In this work, we mainly monitor four parameters of load/transformer that are Voltage, Current.

3.1.1. Voltage Monitoring

First, a 220V/6V step-down transformer is used to transform V_{in} into a lower ac voltage V_1 . i.e, $V_1 = (6/220) * V_{in}$ (1) The output V_1 of the transformer is fed to voltage transformation unit which transforms the input voltage into 5 volts range. The voltage transformation unit consists of diode, Zenner diode and resistive divider network.

- *Load Section*

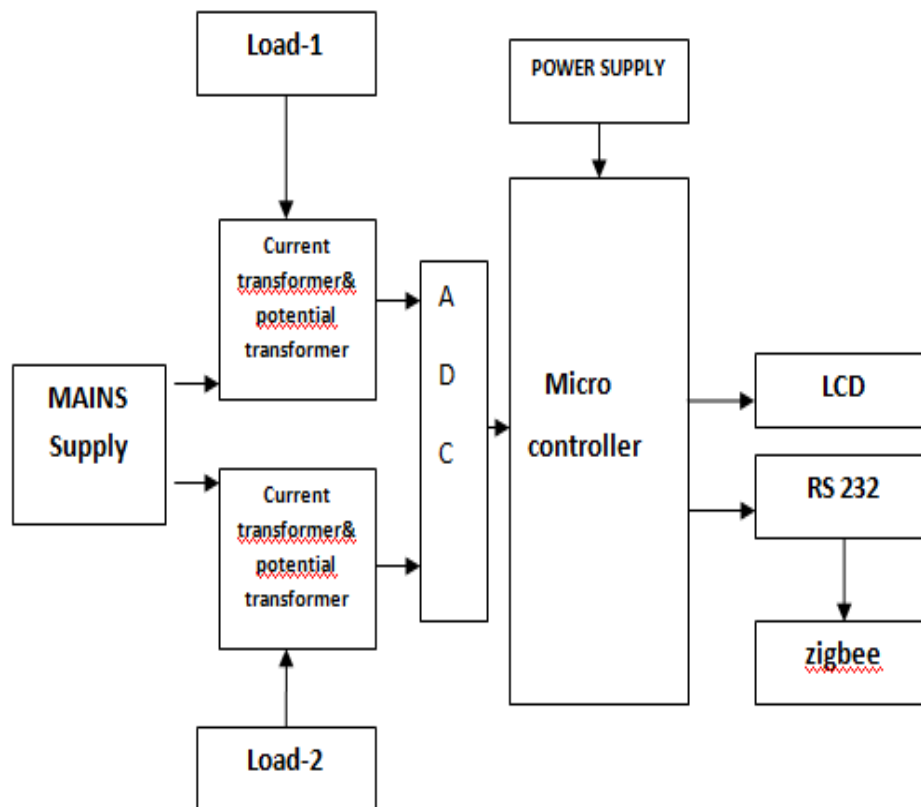

- Monitoring section

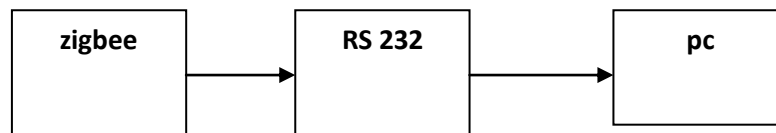

Fig1. Block Diagram of proposed system

3.1.2. Current Monitoring

Current flowing through load/transformer can be measured through the Hall Effect current sensor (ACS712). A current sensor is a device that detects electrical current (AC or DC) in a wire, and generates a signal proportional to it. Hall-Effect current sensors can sense both AC and DC magnetic fields and can generally be specified to operate over a frequency range of DC to several thousand Hertz.

3.2. Zigbee Transmitter Module

ZigBee is a specification for a suite of high level communication on protocols using small, low - power based on an IEEE 802 standard. This network is often used in mesh network form to transmit data over longer distances, passing data through intermediate devices to reach more distant ones [3].

ZigBee specifies operation in the unlicensed 2.4 GHz (worldwide), 915 MHz (Americas and Australia) and 868 MHz (Europe) ISM bands. Transmission range is between 10 and 75 meters (33 and 246 feet) and up to 1500 meters for ZigBee PRO

The XBee Modules are designed to operate within the ZigBee protocol and support the unique needs of low-cost, low-power wireless sensor networks. The modules require minimal power and provide reliable delivery of data between remote devices. The modules operate within the ISM 2.4 GHz frequency band. It operates over a range of 100-200 meters. The receiver module consists of a Xbee module which is connected to computer system through MAX232. Thus the monitoring data received by Zigbee module is directly transferred to computer system.

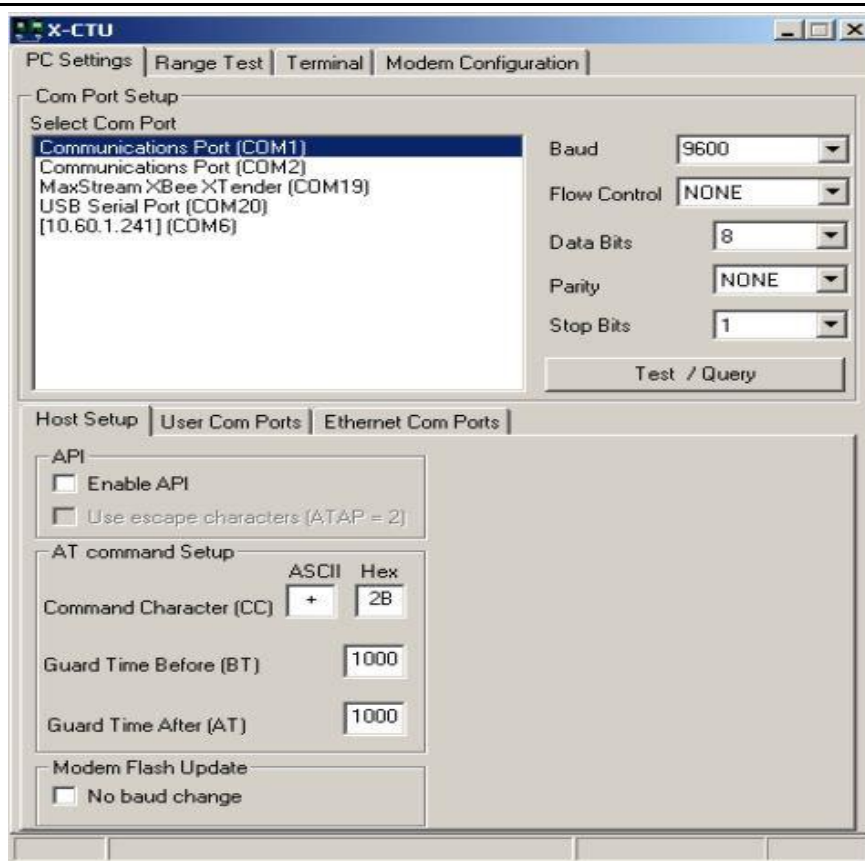

Fig5. X-CTU setup

4. CONCLUSION

With the help of this project, a parameter monitoring system for industrial loads /transformers based on Zigbee protocol is achieved and tested successfully. The system developed is capable to perform such operations as measuring, monitoring and controlling the most parameters of the motor like phase currents, phase voltages. All of these values can be transferred to the host computer, displayed on the interface, represented graphically; Monitoring and controlling the basic parameters of the load/transformer were examined and achieved in various ways. A new ZigBee technology is a new wireless protocol is used for the communication. This protocol is widely used various areas for its better reliability, low power consuming profile, excellent Capability, high flexibility and low cost. So it's significant to embed the ZigBee protocol into the WSN system that widely applied now in every area. The system achieved can be used for industrial applications. The whole system may be very useful to colleges and research institutes that have vocational, technical, and industrial education

REFERENCES

- [1] Tanmoy Maity , Partha sarathi Das , and Mithu Mukherjee, "Rescue and protection system for underground mine workers based on Zigbee " Int. Jr. Of Advanced Computer Engineering & Architecture Vol. 2 No. 2 (June -December,12)
- [2] Jui-Yu Cheng and Min-Hsiung Hung, Jen-Wei Chang, "A ZigBee-Based Power Monitoring System with Direct Load Control Capabilities" Proceedings of the 2007 IEEE International Conference on
- [3] A Comparative Study of Wireless Protocols: Bluetooth, UWB, ZigBee, and Wi-Fi by Jin-Shyan Lee, Yu-Wei Su, and Chung-Chou Shen, Information & Communications Research Labs, Industrial Technology Research Institute (ITRI)
- [4] F.L.Lewis, Wireless Sensor Networks-Chapter 4, Smart environments: Technologies, Protocols, and Applications Journal

- [5] Ramazan BAYINDIR, Mehmet ŞEN, “A Parameter Monitoring System for Induction Motors based on zigbee protocol”, Gazi University Journal of Science. GU J Sci 24(4):763-771 (2011)
- [6] Zulhani Rasin, Mohd Rizal Abdullah , “Water Quality Monitoring System Using Zigbee Based Wireless Sensor Network”, International Journal of Engineering & Technology IJET Vol: 9 No: 10
- [7] Shizhuang Lin¹, Jingyu Liu² and Yanjun Fang,” ZigBee Based Wireless Sensor Networks and Its Applications in Industrial”, International Conference on Automation and Logistics August 18 - 21, 2007, Jinan, China 603