

## Physical Bases of Levitation and Pyrokinesis

Stanislav Konstantinov\*

<sup>1</sup>Department of Physical Electronics, Herzen State Pedagogical University, Saint Petersburg RSC "Energy", Russia

\*Corresponding Author: Stanislav Konstantinov, Department of Physical Electronics, Herzen State Pedagogical University, Saint Petersburg RSC "Energy", Russia

**Abstract:** The article is the first to propose a real mechanism of levitation and pyrokinesis based on Lev Sapogin's Unitary Quantum Theory with a new approach to describing the macroscopic states of a body through a microscopic description of its state in terms of particles, atoms and molecules.

**Keywords:** levitation, pyrokinesis, electron, potential well, oscillation

**PACS Number:** 01.10.Fv, 04.50.-h, 12.10.Kt, 95.36.+x, 98.80.-k

### 1. INTRODUCTION

Historically reliable facts are of the levitation of the Italian monk Giuseppe Desa (1603-1663) and the nun from Avila Sister Theresa (1520-1580). Falling into religious ecstasy, both of them repeatedly against their will broke away from the Earth and hovered at an altitude of several meters and above. At the same time, their bodies vibrated at a certain frequency, representing an analogue of a physical oscillator. In Tibet, the founders of the practice of levitation were the monks of the Shaolin monastery. In India and Tibet, the art of levitation has survived to this day. Currently, the greatest results in the field of levitation have been achieved by those who use the yoga technique. Within the framework of the modern scientific paradigms, based on the theory of relativity of Albert Einstein and quantum mechanics by Niels Bohr, levitation and pyrokinesis (spontaneous combustion of a person) remain a mystery, but in the new physics based on Lev Sapogin's Unitary Quantum Theory and recognition, along with the existence of four fundamental interactions: electromagnetism, as well as strong and weak nuclear interactions, the fifth interaction (fifth force) between baryonic and dark matter, the answer can be found.

### 2. MICROSCOPIC LEVEL OF DESCRIPTION OF FLUCTUATIONS IN TERMS OF ELEMENTARY PARTICLES AND ATOMS AND MACROSCOPIC LEVEL OF DESCRIPTION OF THE EFFECTS OF LEVITATION AND PYROKINESIS.

To solve the problem of human levitation and pyrokinesis, let us consider the approaches of the Unitary Quantum Theory of Professor Lev Sapogin to the description of elementary particles and atoms. Let us turn to the behavior of electrons in a potential well in Lev Sapogin's theory [1]. In the UQT, the equation with an oscillating charge is essentially Newton's equation for the movement of a charge in an external potential, but the amount of charge depends on time, speed and coordinates [2]. When solving the problem of a harmonic oscillator, in addition to the usual stationary solutions, 2 more new solutions arise (Fig. 1), which were named Crematorium and Maternity Home. In the first solution, the particle oscillates in a potential well with an exponential decrease in energy, and in the second solution, its energy increases (for a parabolic well, it is unlimited).

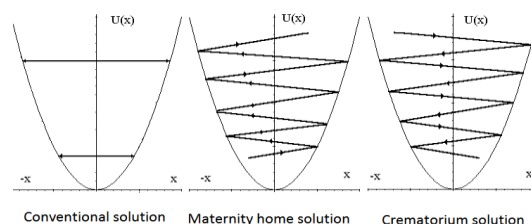

Figure1. UQT solutions for particle oscillations in a potential well

The autonomous movement equation in the case of a potential well in the shape of hyperbolic secant  $U(x) = -U_0 \operatorname{sech}(x^2)$  will look as follows:

$$m \frac{d^2x}{dt^2} + \frac{4U_0 Q x \cos^2\left(-m x \frac{dx}{dt} + \varphi_0\right) \sinh(x^2)}{\cosh^2(x^2)} = 0 \quad (1)$$

where  $x$  is the coordinate of the particle as a function of time;

$m, Q, \varphi_0$  is mass, charge and initial phase of the particle.

It turns out that the nature of the trajectory of a particle under the same initial conditions depends very strongly on the initial phase [2].

At  $\varphi_0 = 0.1$ , the particle rolls into the hole and is reflected with greater energy. Under the same initial conditions and at  $\varphi_0 = 0.2$ , an oscillation of a particle in the well with almost the same energy is observed, and at  $\varphi_0 = 3.2$ , an increase in oscillations inside the well (Maternity Home) is observed up to an energy sufficient to exit the well [2]. Where does the electron in the potential well get additional energy, thereby violating the law of conservation of energy? Professor L. Sapogin, having discovered such a solution for an equation with an oscillating charge, showed that a physically similar solution arises for the Schrödinger equation [1]. Let the potential in the Schrödinger equation be  $U(x) = rx$ . Then the complete Schrödinger equation will take the form:

$$\frac{\hbar^2}{2m} \frac{d^2\Psi(x,t)}{dx^2} - rx\Psi(x,t) + i\hbar \frac{d\Psi(x,t)}{dt} = 0 \quad (2)$$

We will seek the solution in rather unusual form:

$$\Psi(x,t) = b \exp\left(i \frac{m\alpha^2 t^3}{2\hbar} - i \frac{m\alpha x}{\hbar}\right) \quad (3)$$

But substituting (3) in (2) we get (after reducing):

$$-2m\alpha^2 t^2 + (m\alpha - r)x = 0 \quad (4)$$

This relation will be fulfilled if

$$x = \frac{2m\alpha^2}{m\alpha - r} t^2 \quad (5)$$

If in (2) impose the requirement  $r \rightarrow 0$  (potential vanishes), then absolutely strange particular solution appears where the particle is able to move with constant acceleration and to generate energy no of an unknowns where origin (!!!). That effect remains valid even if we put  $r \rightarrow 0$  directly in equation (2). Such a solution of the equation (2) for wave function with increasing frequency (energy) has been discovered independent from us by Dr. Bill Page – USA in the form of combinations of Airy functions. The same solutions can be obtained for Dirac equation. Curious, but we have similar situation in classical electrodynamics. If during acceleration of a charge one takes into account force acting on a charge itself, then the braking due to radiation arises. In different works this effect is called in different way: Lorenz frictional force or Plank's radiant friction. That force is proportional to third derivative of coordinate  $x$  relative to time and was experimentally proved many years ago. If we write the equations of motion for the charge moving in space free from external fields impact and if the only force acting on the charge is the "Plank radiant friction", then we would obtain following equation:

$$m \frac{d^2x}{dt^2} = \frac{2e^2}{3c^3} \frac{d^3x}{dt^3} \quad (6)$$

It is evident that equation in addition to trivial particular solution  $v = dx/dt = \text{Const}$  has general solution where particle acceleration is equal [1]:

$$\alpha = \frac{d^2x}{dt^2} = C \exp\left[\frac{3mc^3 t}{2e^2}\right] \quad (7)$$

i.e. is not only unequal to zero, but more over it unrestrictedly exponentially increases in time for no reason whatever!!!

L. Landau and M. Lifshitz in their classic book "Field Theory" write the following about this: "The question may arise of how electrodynamics satisfying the law of conservation of energy can lead to an absurd result in which a free particle increases its energy. The roots of this are in the infinite

electromagnetic “own mass” of elementary particles”[3]. I will allow myself to disagree with the classics. In new physics, the recognition of the polarization of the quantum vacuum (dark matter) in the theories of quantum electrodynamics (QED) and quantum chromodynamics (QCD) leads to the violation of symmetries, conservation laws and prohibitions in the Standard Model. The fifth fundamental interaction between baryonic and dark matter (the fifth force) causes a rejection of the paradigm of the evolution of a closed Universe and requires a revision of all laws of conservation and symmetry. Nobel Prize laureate I. Prigogine, studying the dynamics of systems development and, in particular, the growth of entropy, found that “in a steady state, the active influence from the outside on the system is insignificant, but it can be of great importance when the system passes into a nonequilibrium state. In this case, the system becomes non-integrable, time loses its invariance and its behavior is probabilistic”[4]. The dynamics of the bodies of monks hovering above the Earth, whose cells vibrate into resonance like a large resonator in a gravitational field, can be explained from the standpoint of the Unitary Quantum Theory, when the fluctuations were first localized in atoms, then spread to the entire body of the monk and brought it into a new macroscopic state. This situation radically changes the traditional concepts of a microscopic description of a state in terms of particles, atoms and molecules, and a macroscopic description in terms of concentrations, densities, and volumes.

In a nonlinear oscillator, even with a sinusoidal external influence, the dynamics of the system can turn out to be extremely complex, similar to a random one. In this case, a dynamic stochasticity regime appears in the system. Several potential wells correspond to several resonances. The overlapping of resonances means that such a convergence of neighboring wells occurs when a particle can move from well to well and, under certain conditions, leave them. With such transitions, a new type of instability of nonlinear systems appears - stochastic instability [5]. Let's consider this mechanism in more detail. If the oscillator is linear, then in the representation  $\omega^2(x) = \omega_0^2 + \alpha x + \beta x^2 + \dots$  the square of the natural frequency in the form of a power series in terms of the amplitude of oscillations, we restrict ourselves only to the first term, and when an external periodic force acts on the oscillator, the only main effect is observed - linear resonance. In this case, the smaller the loss in the oscillator, the sharper and higher the resonance curves. What will change if the frequency depends on the amplitude of the oscillations? Let the frequency of the external influence be equal to the frequency of rotation along one of the phase trajectories near the center. Then the system draws energy from an external source, and small at first oscillations increase. This means that the particle moves sequentially to those phase trajectories that correspond to a large energy, but since the oscillator is non-isochronous, a different frequency corresponds to large energies. As a result, the system leaves resonance and, starting from a certain amplitude, the oscillator ceases to notice the external force. Thus, the exit from resonance occurs due to the nonlinear frequency shift  $\omega = \omega(x)$ . What new effects appear in the behavior of a nonlinear oscillator at resonance? In a linear oscillator, there are resonances only at a frequency close to its own, i.e.  $\Omega = \omega_0 \pm \varepsilon$ , where  $\varepsilon$  is a small addition. For a nonlinear oscillator, there is also a resonance at harmonics; for example, quadratic nonlinearity leads to the appearance of spectral components  $2\Omega, 4\Omega$ , etc. in a nonlinear system. (anharmonicity of vibrations). Therefore, if, for example,  $2\Omega = \omega_0$ , then the system will have a resonance at the harmonic of the external force. A regime of dynamic stochasticity appears in the system. If the dynamics of a particle in an oscillator is usually understood as a completely deterministic process, the entire past and future of which is uniquely determined by the equations of motion and initial conditions, then the concept of stochasticity is associated with some kind of randomness, some kind of uncertainty. Is it possible for a strictly deterministic process to be random at the same time? Yes, perhaps L. Sapogin answers at the UKT. His physical and mathematical research shows that this is not only possible, but under certain conditions and inevitable. It should be noted that for dynamic stochasticity in systems without dissipation, the main thing is non-isochronism. Indeed, the effect of increasing or decreasing the vibration energy due to disturbances is determined by its phase. The phase depends on the frequency, which, due to isochronism, changes under the influence of perturbations. In the case of a single resonance, as mentioned above, the system can exit from it. But if there are many resonances (at least two), a complex picture of the system's motion arises due to their interaction. Now, depending on the phase of the disturbance, the system can either move further into the region of the next resonance and eventually leave the well, or return back. This state of the system is called "resonance overlap" [5].

Similarly, the uncontrolled release of heat in the cells of the body during the implementation of the UCT Maternity Home solution can lead a person to spontaneous combustion (pyrokinesis). A similar effect is seen in Andrea Rossi's E-Cat reactor. The reactor is a ceramic tube in which nickel powder is placed under pressure with hydrogen (Figure 2).

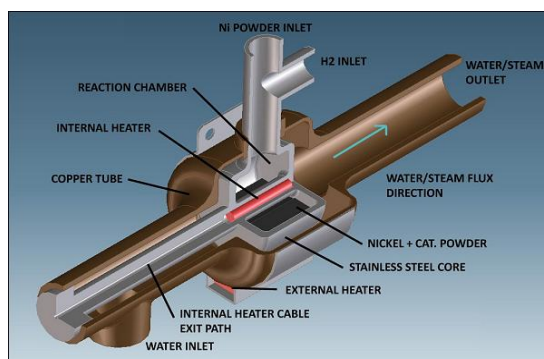

Figure2. Andrea Rossi E-Cat Reactor

In the presence of electric current, the system heats up and generates 3-50 times more heat than it consumes. Professor Lev Sapogin explains the excess energy in the E-Cat reactor by Andrea Rossi from the standpoint of the UKT [6]. Nickel grains (these can be grains or the smallest crystals) in the E-cat have cavities tens of angstroms in size (they work as potential holes); a proton of the corresponding phase can penetrate into the cavity, and heat is released as a result of numerous impacts against the borehole walls. In this case, the proton draws energy from the environment (dark matter). In 2014, Rossi provided his facility for independent 30-day tests, during which two different laboratories conducted an isotopic analysis of the initial substance (fuel) and the spent substance after the tests. The analysis showed that the initial statement about the transmutation of nickel into copper is not true. In practice, the installation of Rossi is the transmutation of nickel-58,60,61 to nickel-62, as well as lithium-6 to lithium-7. Independent tests showed that the heat dissipation in the Rossi unit during the 30-day test was 5.8 GJ per 1 gram of fuel. The power of energy release is about 2 MW / kg, for comparison, the power output of the VVER-1000 is 111 kW / 1 of the core or 0.035 MW / kg of fuel. Thus, the energy release of TVEL in the Rossi facility is approximately 50 times more than that of modern nuclear reactors in TVEL, which is quite consistent with nuclear fusion reactions. The first generator, generating industrial steam with a temperature of 600 ° C, Rossi thinks to submit at the beginning of 2019 "to prove his rightness and confirm the expectations of partners and sponsors, as well as all supporters and enthusiasts of LENR" (conventional efficiency of such generators is expected to be at least 600%) . At the same time, he is developing a single-module reactor of the SK type ("Sven Kullinger") with a power of 1 kW. It should be noted that the recognition of the E-Cat reactor by Andrea Rossi leads to the violation of symmetry, conservation laws and prohibitions in the Standard Model and still cannot be explained within the framework of the existing paradigm. There is surprising evidence of the catalytic decomposition of  $H_2S = H_2 \uparrow + S \uparrow$  with an exothermic catalytic reaction, and  $H_2 + S = H_2S$  also generate heat. Both of these reactions require no energy. Assessing the thermodynamics processes L.Sapogin the above states: "But this is a direct violation of the Law of Conservation of Energy in terms of thermodynamics! A catalyst, according to modern concepts, does not add additional energy to the process that it catalyzes. However, practice shows that the catalyst brings additional energy! [6]. The question arises of cold nuclear fusion as a source of energy in all of the above cases, including pyrokinesis. It was discovered long ago that nuclear transmutations are widely spread (it is especially evident for plants and biological objects), but they are faintly connected with energy liberation. The examples of such reactions are:



In reactions of such a type very slow proton (its kinetic energy is equal practically to zero) is penetrating inside the nucleus by the abovementioned way and stays there. There is no nuclear energy liberation, because the nucleus remains stable both before and after reaction. In accordance with

classical nuclear physics, the nucleus, as usual, after a charged proton with great kinetic energy gets inside it, becomes unstable and breaks to pieces, and its fragments obtain bigger kinetic energy. The reactions of above-mentioned type were considered impossible at all at small energies and therefore were not studied in the classical nuclear physics. Apparently, that is absolutely new type of nuclear transmutations unacknowledged by modern nuclear science, but experimentally discovered sufficiently long ago. Today there are a lot of experimental data confirming the mass character of nuclear transmutation [1].

### 3. CONCLUSION

Thus, for the first time it is proposed to solve the riddle of levitation and pyrokinesis as macroscopic states of the body, through its microscopic states, described by individual particles, atoms and molecules from the point of view of quantum field theory. In the effect of levitation, bringing all the oscillating particles of the body to one initial phase  $\varphi_0$ , in order to realize an overlapping resonance in the constant gravitational field of the Earth, is achieved by prolonged training in the Yoga system from Buddhist monks of Tibet and India or by unconscious religious ecstasy among Catholic monks. The effect of pyrokinesis occurs spontaneously and is associated with intracellular nuclear transmutations. The source of energy in this case can be cold nuclear fusion [7].

### REFERENCES

- [1] Leo G. Sapogin, Yu.A Ryabov, V.A. Boichenko, "The Unitary Quantum Theory and a New Sources of Energy". - Science Publishing Group, USA. (2015)
- [2] Leo G. Sapogin, Ryabov Yu.A. "Equations with Oscillating Charge in Unitary Quantum Theory", Applied Physics Research Vol. 3, No. 2; November 2011, [www.ccsenet.org/apr](http://www.ccsenet.org/apr)
- [3] Landau L. D., Lifshits E. M. "Theoretical Physics, Field Theory, Volume 2," Fizmatgiz Publishing House, 1960
- [4] Prigogine I.R., Stengers I., "Time, chaos, quantum", Moscow: Progress, 1994
- [5] Trubetskov D.I. An introduction to syneretics. Chaos and structure, M.: URSS, 2004
- [6] Leo G. Sapogin, Vladimir A. Dzhanibekov, Yuri A. Ryabov "Enigmatic E-Cat of Andrea Rossi and the Unitary Quantum Theory", Open Access Library Journal, Vol.3, No.7, (July 2016)
- [7] Stanislav Konstantinov, "Nuclear fusion: the management prospects", Physics & Astronomy International Journal, Volume 2 Issue 6 - 2018

**Citation:** Stanislav Konstantinov, (2020). *Physical Bases of Levitation and Pyrokinesis*. *International Journal of Advanced Research in Physical Science (IJARPS)* 7(10), pp.18-22, 2020.

**Copyright:**© 2020 Authors, This is an open-access article distributed under the terms of the Creative Commons Attribution License, which permits unrestricted use, distribution, and reproduction in any medium, provided the original author and source are credited.