

## Review of Extraction Techniques

### *Extraction Methods: Microwave, Ultrasonic, Pressurized Fluid, Soxhlet Extraction, Etc*

Komal Patel<sup>1</sup>, Namrata Panchal<sup>2</sup>, Dr. Pradnya Ingle<sup>3\*</sup>

<sup>3</sup>Associate Professor

Department of Chemical Engineering,

Shivajirao S. Jondhale College of Engineering, Dombivli (East), 421201, University of Mumbai, India.

**\*Corresponding Author:** Dr. Pradnya Ingle, Associate Professor Department of Chemical Engineering, Shivajirao S. Jondhale College of Engineering, Dombivli (East), 421201, University of Mumbai, India.

**Abstract:** In recent years, variety of Extraction techniques has been introduced for the recovery of organic compounds. Extraction Methods are widely used in various Industries for Separation of components and has wide range of applications. Details of basic theories applicable to types of Extraction such as - Liquid- Liquid Extraction, Solid Phase Extraction, Solid Liquid Extraction and Supercritical Extraction, etc. including the choice of solvent, procedure, respective advantages disadvantages and their applications are explained. Finally, the specific extraction techniques such as Microwave Extraction, Ultrasonic Extraction, Pressurized Fluid Extraction and Soxhlet Extraction along with their applications are also explained.

**Keywords:** Extraction, Liquid-Liquid Extraction, Solid Phase Extraction, Solid Liquid Extraction, Supercritical Extraction, Microwave Extraction, Ultrasonic Extraction, Pressurized Fluid Extraction, Soxhlet Extraction.

### 1. INTRODUCTION

In Extraction the mixture of substances is dissociated, by dissolving each component with one or other solvents which yields two phases – Raffinate Phase (rich in Feed Solvent) and Extract Phase (rich in Solute) [1]. When the Relative Volatility is 1 the separation of the components in the mixture is not possible by Distillation and when relative Volatility is Greater than 1 Extraction method is used for separation of the components. Also, when the Distillation Method used is too expensive, Extraction process is opted [2]. The basic Block Diagram for Extraction process is given in the Fig1.

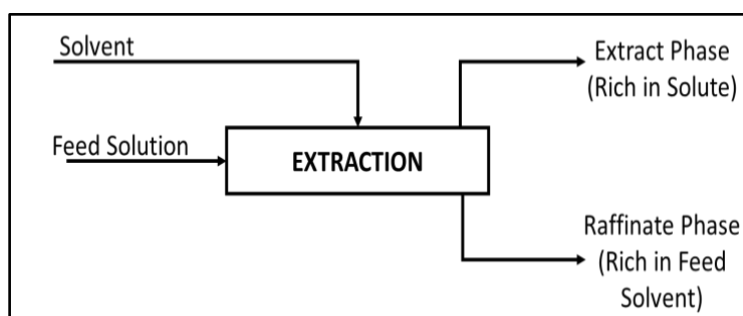

**Fig1.** Block Diagram for Extraction

Classification of Extraction process is based on two different categories namely, Operation and Types of Phases [3].

- Classification based on Operation: Batch Process
  - Continuous Process
- Classification based on Types of Phases:

- Liquid- Liquid Extraction – Sample Phase (Liquid)  
Extract Phase (Liquid)  
Basis for Separation (Partitioning)
- Solid Phase Extraction or – Sample Phase (Gas, Liquid)  
Micro-extraction Extract Phase (Liquid, Solid, Stationary Phase)  
Basis for Separation (Partitioning or adsorption)
- Leaching or Solid Liquid – Sample Phase (Solid)  
Extraction Extract Phase (Liquid)  
Basis for Separation (Partitioning)
- Supercritical Fluid - Sample Phase ( Solid, Liquid)  
Extraction Extract Phase (Supercritical Fluid)  
Basis for Separation (Partitioning with applied heat)

Advance Extraction Techniques – Microwave assisted Extraction (MAE), Ultra sonication assisted Extraction (UAE), Supercritical Fluid Extraction (SFE), Soxhlet Extraction, Soxtec Extraction, Pressurized Fluid Extraction (PFE) or Accelerated Solvent Extraction (ASE), Shake Flask Extraction and Matrix Solid Phase Dispersion (MSPD) [4].

## 2. TYPES OF EXTRACTION

### 2.1. Liquid-Liquid Extraction

It is also known as Solvent Extraction refers to an operation in which the components of the liquid mixture are separated by contacting it with a suitable insoluble liquid solvent which preferentially dissolves one or more components [13]. In this type of operation, the separation of the components of solution depends upon the unequal distribution of the components between two immiscible liquids. In liquid extraction the feed solution is one phase and the solvent used for extraction is another phase. In solvent extraction both the liquids i.e. the feed and solvent forms a homogenous mixture and are separated by contacting it with one another which separates out one of the two liquids preferentially [15].

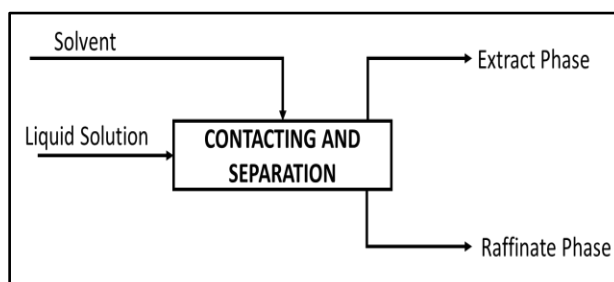

**Fig2.** Block Diagram for Liq-Liq Extraction

#### Notation Adopted:

- a) A is the feed solvent, B is the extracting solvent (A and B are pure and substantially insoluble liquids) and C is the solute that will distribute between two phases.
- b) F – Feed solution to be separated by extraction which comprises of A and C.  
E – Extract or Extract phase.  
R – Raffinate or Raffinate Phase [13-14].

#### Overall Material Balance,

Liquid Solution + Solvent = Extract Phase<sub>(liq)</sub> + Raffinate Phase<sub>(liq)</sub>

$F + B = E + R$

#### Example:

Extraction of Methanol from LPG with water [14].

The contacting of a solution of Acetic acid in water with a solvent such as ethylacetate forms two phase the extract (ester layer / organic layer) phase which contain most of the acetic acid in ethylacetate with some water, while the raffinate phase (aqueous layer) which contains weaker acetic acid solution with a small amount of ethylacetate [13]. The amount of water in extract phase and ethylacetate in raffinate phase depends upon their solubility's into one another [15].

### 2.1.1. Selection of Solvent for Extraction

Solvent selection is based on the qualities of solvent such as selectivity, recoverability, distribution coefficient, density, etc.

Selectivity – The ratio of concentration of solute to feed solvent in the extract phase to that in the raffinate phase is called the selectivity, which can also be known as separation factor. It is the measure of effectiveness of the solvent for separating the constituents of a feed [16-19].

$$\beta = \frac{\frac{[Wt. fraction of C]}{[Wt. fraction of A]} (for E)}{\frac{[Wt. fraction of C]}{[Wt. fraction of A]} (for R)}$$

$\beta > 1$  – Extraction is possible.

$\beta = 1$  – Extraction not possible.

This means higher the selectivity; the easier would be the separation.

Recoverability – Solvents are recovered and reused by distillation, but they should not form an azeotrope with the extracted solute. If the relative volatility is high, the cost of recovery is low. Also the latent heat of vaporization should be low [16-19].

Distribution coefficient – It is the ratio of concentration of solute in extracts phase and raffinate phase. It is denoted by K [16-19].

$$K = \frac{C_E}{C_R}$$

Higher values of Distribution Coefficient are generally desirable as then less amount of solvent and less number of extraction stages are required for a given extraction duty.

Density – For physical separation of phases the densities of saturated liquid Phase should be larger [16]. Solvent should be cheap, non-toxic and non-flammable [19].

### Solvents for Liquid – Liquid Extraction

| Aqueous solvents | Water – Immiscible organic solvent |
|------------------|------------------------------------|
| Basic Solution   | Dichloromethane                    |
| Acidic Solution  | Diethyl ether                      |
| Water            | Hexane, Petroleum Ether            |
| High Salts       | Chloroform                         |

Application of liquid-liquid Extraction are as follows- Liquid- Liquid extraction is widely used in Decaffeination of coffee and tea and separation of essential oils (flavors and fragrances) in Food Industry; most probably used in separation of olefins/paraffin and structural isomers in Petrochemical Industries; most efficiently used in recovery of active materials from fermentation broths and purification of vitamin products in Pharmaceutical Industry; essential in improvement of lube oil quality and in separation of aromatics/aliphatic (BTX) in Petroleum Refinery; in Nuclear Industry Liquid- Liquid Extraction is used for purification of Uranium [20-21].

### 2.2. Solid Phase Extraction

Solid Phase Extraction is sample Preparation Method used for isolation, enrichment and purification of components from aqueous solutions depending upon their physical and chemical properties [24]. This involves contacting of aqueous samples with a solid phase or sorbent, where the compound is adsorbed on the surface of the solid phase prior to elution [28]. The Extract amount is negligible compared to quantity of analyte in the sample. Solid Phase Extraction is widely used in Analytical Laboratories.

It also overcomes issues faced in the Liquid-Liquid Extraction Operation, such as phase separation is not satisfactory, less recovery, waste of large amounts of organic solvents. Also, the glassware used is expensive in liquid- liquid extraction [29].

Sorbent – It is a material used to adsorb or absorb different fluids [25].

### 2.2.1. Different Types of Packing's Used on Solid Phase Extraction

The packing's used in Solid Phase Extraction are based on the particle size. The Table 2.1 shows the different types of packing used based on particle size [28].

**Table 2.1.** Types of Packing based on particle size

| Type of Packing    | Size of Particles                | Phases             |
|--------------------|----------------------------------|--------------------|
| Silica             | 40µm particles, 60 Å pores       | Reversed Phase     |
|                    |                                  | Ion Exchange Phase |
|                    |                                  | Normal Phase       |
| Alumina            | Irregular particles, 60/325 Mesh | Adsorption Phase   |
| Florisil           | Particles of 100/200 Mesh        | Adsorption Phase   |
| Resin              | (Spherical Particles) 80-160 µm  | Adsorption Phase   |
| Graphitized Carbon |                                  | Adsorption Phase   |

### 2.2.2. Types of Phases

#### Reversed Phase (Fig2.):

In Reversed Phase the mobile phase is polar and stationery phase is non-polar (Hydrophobic). Typically 8 or 18 carbons are added to Silica. Silica C18 is non-polar. The nonpolar molecules binds or adsorbs to it and the polar molecules will pass more quickly through the stationery phase.

Reversed phase is easier to use. Also, this phase has a hydrophobic stationery phase which can be applied to a wide range of molecules, it works well in retention time for most of the organic analytes (70-80% of common analytes can be measured by using this technique). It also allows precise control of variables such as organic solvent type, concentration and pH. Reversed phase has more options in Chromatography field [29].

The applications are Extraction of CCl<sub>4</sub> from Drinking Water, The washing water used in olive oil processing contains pesticides that are extracted and Pre-concentration of Photo-inhibitors in Beverages.

#### Normal Phase (Fig3.):

The column is filled with Silica particles. The Silica is polar. The polar molecules binds/ adsorbs to it and the non-polar molecules will pass more quickly through the stationery phase.

Normal phase can be used for compounds that are too hydrophobic for separation. Compounds that are not soluble in water or that may decompose in water undergo this phase. One of the main use of normal phase is for separation of isomers [29].

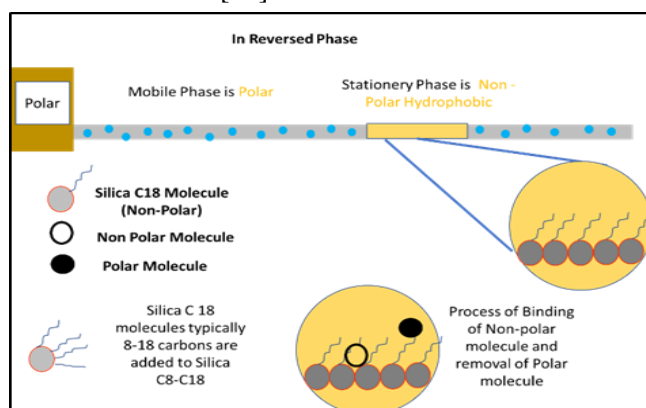

**Fig3.** Reversed Phase

The applications are Quantitative Analysis of Chlorinated Pesticides obtained from Fish Extracts, Separation of Molecular Constituents from the main components of organic matter from the soil and Extraction of Fatty acids from Shellfish Extracts.

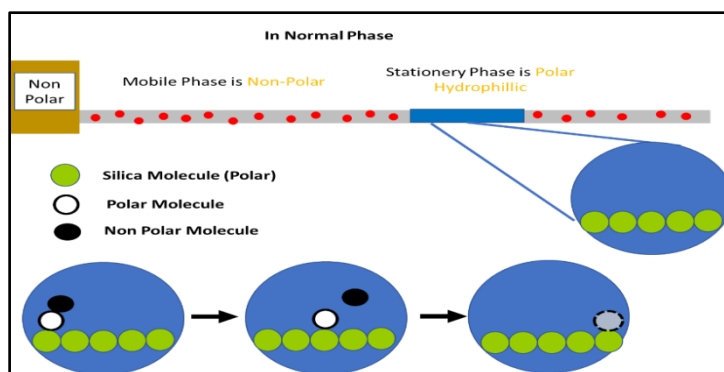

Fig4. Reversed Phase and Normal Phase

### Ion Exchange Phase:

Ion Exchange Solid Phase Extraction is used for separation of ionic compounds from either polar solvent or non-polar solvent in the presence of oppositely charged ion exchange solvent. Ion Exchange media comes in both anionic and cationic forms for the extraction of analyses with basic or acidic functional group [37]. Ion Exchange sorbents can be further sub classified as either weak or strong exchangers depending upon the type of ionic group bonded to the surface. Strong cation exchangers include acidic functional group such as derivatives of sulphonic acids. Weak cation exchangers have surface functional group that are negatively charged at high pH but neutral at low pH [29]. The applications include Isolation of constituents of proteins (Amino Acids) from Liquid Samples and Formation of Cationic Selenium Compounds present in *Brassica juncea* leaf extracts.

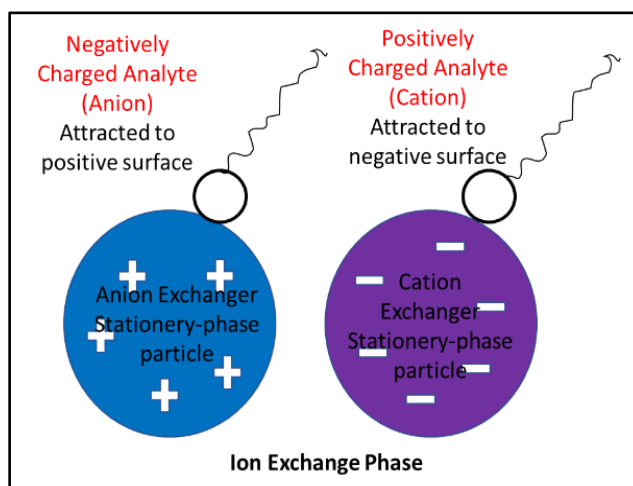

Fig5. Ion Exchange

### 2.2.3. Selection of Solvent

Table 2.2. Commonly used Solvents in Solid Phase Extraction

| Polarity                |   |   | Solvent              | Miscible in water |
|-------------------------|---|---|----------------------|-------------------|
| Non-polar<br>↓<br>Polar | Strong Reversed Phase<br>↑<br>Weak Reversed Phase | Weak Normal Phase<br>↓<br>Strong Normal Phase | Hexane               | No                |
|                         |   |   | Carbon tetrachloride | No                |
|                         |   |   | Dichloromethane      | No                |
|                         |   |   | Ethyl acetate        | Poorly            |
|                         |   |   | Acetone              | Yes               |
|                         |   |   | Methanol             | Yes               |
|                         |   |   | Acetic Acid          | Yes               |

### 2.2.4. Steps involved in Solid Phase Extraction

The Solid Phase Extraction Operation is divided into five steps as follows:

Step 1: Wetting of Sorbent.

Step 2: Conditioning of sorbent.

Step 3: Loading of sample.

Step 4: Interference Elution.

Step 5: Analytic Elution.

Rinse the SPE tube with sorbent and add sufficient amount of sorbent in it. This is followed by conditioning of sorbent in which the solvent or buffer is added. The next step is loading of samples. The sample is forced through the sorbent material by suction (Vacuum or plunger). This process is followed by washing with solvent where the unwanted material are removed by extracting one material from other (Elution). This helps in extraction of desired sample. Lastly the Desired sample is extracted from the sorbent with the help of elute solvent [37].

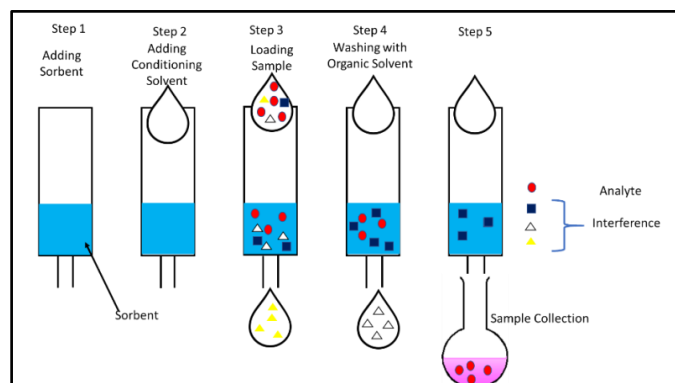

**Fig6.** Steps involved in Solid Phase Extraction

### 2.3. LEACHING (SOLID-LIQUID EXTRACTION)

Solid -Liquid Extraction (Leaching) means the removal of constituents from a mixture of solids by bringing the solid material into contact with a liquid solvent that dissolves this particular constituents [30]. Leaching may either be used for production of concentrated solution of a valuable solid material, or in order to free an insoluble solids from a soluble material with which it is contaminated. An everyday example of leaching is making coffee. In this case the soluble constituents i.e. the ground coffee is separated from insoluble grounds by solution in water [31].

#### 2.3.1. Mechanism of Leaching

Leaching involves two steps which are as follows:

##### 1) Contacting step

Contacting the solid with the selective solvent - the liquid in order to dissolve the soluble solute in the solvent. The solute is first dissolved from the surface of the solid, then passes into the main body of the solution by diffusion. This process may result in formation of pores in the solid material which exposes new surfaces to subsequent solvent penetration to such surface [32].

##### 2) Separation step

Separation of insoluble phases, i.e. separation of liquid phase from solid physically by settling, filtration, etc.

#### 2.3.2. Methods of Operation

##### 1) Single Stage Leaching (Crosscurrent)

Consider a theoretical extraction stage.

$F$  – mass of A+C in solids to be leached.

$Y_F$  – mass of C per mass of A+C in solids to be leached.

$R_o$  – mass solution A+ C in leaching solvent.

$X_o$  – mass of C / mass of A+C in leaching solvent.

$E_1$  – mass A+C in leached solid.

$Y_1$  – mass C/mass of A+C in leached solids.

$R_1$  – mass solution A+C in overflow.

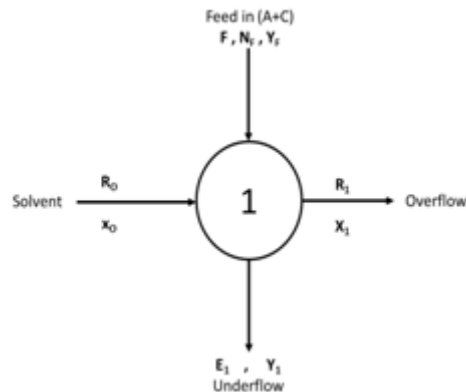

$X_1$  – mass C / mass A+C in the leach solution (overflow) Overall Material Balance

$$F + R_0 = R_1 + E_1$$

Component Material Balance

$$F * Y_F + R_0 * X_0 = R_1 * X_1 + E_1 * Y_1$$

2) Multistage Crosscurrent Leaching

Material Balance for stage 1 is similar to single stage Material Balance.

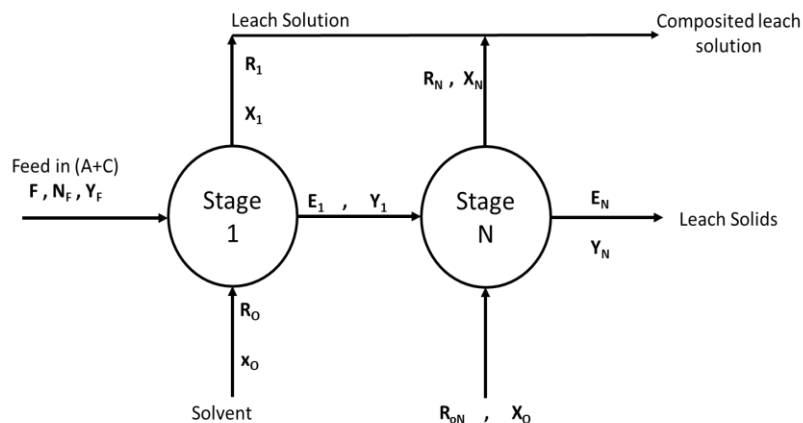

Material Balance of Stage N,

Overall Material Balance,

$$E_{N-1} + R_{0N} = E_N + R_N$$

Component Material Balance,

$$E_{N-1} * Y_{N-1} + R_{0N} * X_0 = E_N * Y_N + R_N * X_N$$

3) Multistage Countercurrent Leaching

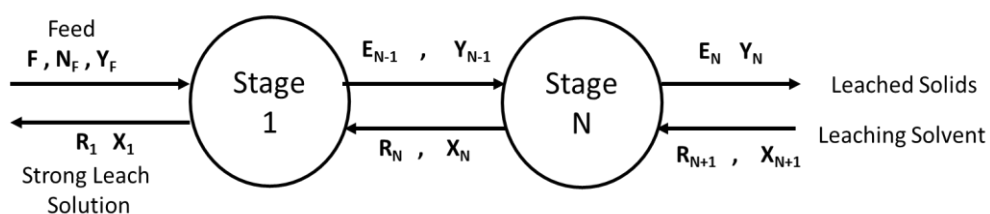

Material Balance for N stage,

Overall Material Balance,

$$E_{N-1} + R_{N+1} = E_N + R_N$$

Component Material Balance,

$$E_{N-1} * Y_{N-1} + R_{N+1} * X_{N+1} = E_N * Y_N + R_N * X_N$$

Applications of Leaching Operation are as follows - Leaching of sugar from sugar beets using hot water; Extraction of oils from oilseeds such as soya been using hexane or petroleum ether as a solvent; Extraction of tannin from tea barks using water; Extraction of perfume from flowers; Extraction of medicinal compounds such as fine pharmaceuticals from plant roots, leaves and stems in pharmaceutical industry [34-36].

## 2.4. Supercritical Fluid Extraction

In this type of Extraction a component is extracted from a matrix with the help of solvent. But here the solvent used is Supercritical Fluid. Supercritical Fluid Extraction ( SCF) is usually performed for extraction from solids, but this process is also valid for extraction from liquids. Extraction of this type is used for preparation of samples in analytical laboratories. On larger Scale it is being used for removal of unpalatable material (Decaffeination) form the product stream (oil) [38, 37].

In this Extraction process the separated compounds or chemicals are combined with the supercritical fluids, which give rise to a mobile phase. At temperature and pressures (approximate to the critical temperature and pressure conditions) the mobile phase is enhanced with the solvating properties[39].

Supercritical Fluid: Such types of fluids are of high density and non-compressible. The Fig.2.6 , represents the Pressure Versus Temperature profile for fluids. The Pressure and Temperature of Supercritical Fluids is higher than the critical point. Thermal motion of these fluids is high, also the density can be widely varied. Hence, it possible to control the properties that relates to density. In Decaffeination process the frequently used solvent is Carbon dioxide, on the other hand for power generation purpose the supercritical fluid used is water [41,42].

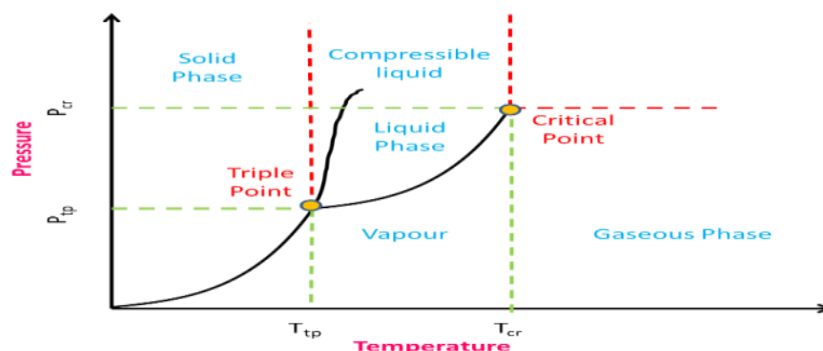

Fig7. Pressure versus Temperature profile for Supercritical fluids

## Solvents used in Supercritical Extraction

The critical properties of the solvents are mentioned in the Table. 2.3[38].

| Solvents                                  | Molecular Weight (g/mol) | Critical Temperature (°C) | Critical Pressure (atm) | Critical Density (kg/m <sup>3</sup> ) |
|---|--------------------------|---------------------------|-------------------------|---------------------------------------|
| CO <sub>2</sub>                           | 44.01                    | 31.2                      | 73                      | 467.6                                 |
| CH <sub>4</sub>                           | 16.04                    | -82.6                     | 45                      | 162.7                                 |
| Ethylene (C <sub>2</sub> H <sub>4</sub> ) | 28.05                    | 9.2                       | 50                      | 214                                   |
| CH <sub>3</sub> OH                        | 32.04                    | 240.2                     | 81                      | 281                                   |
| Acetone (C <sub>3</sub> H <sub>6</sub> O) | 58.08                    | 235                       | 46.3                    | 273                                   |

Supercritical Fluid Extraction Method is a simple operation. The time required for quick extraction is about 30-60 minutes per sample, which is 1/3<sup>rd</sup> to 1/4<sup>th</sup> of the processing time required by conventional techniques. This technique eliminates trace pesticides and the extract is collected in a trap column. Minimum extract can also be separated in the trap column. The trap column and piping is washed after each set of operation which ensures minimum blockages and contamination in the column. Carbon



dioxide is used as a extracting solvent and is highly pure and inexpensive for SCF Extraction. This technique is safe and environmental friendly because carbon dioxide is non-toxic and non-flammable.

Physical and thermal properties of SFFs are in between pure liquid and gas, hence can also be known as “Compressible liquids” or “dense gases”[42].

Changes in properties for a SCF

- Liquids like densities (100-1000 times greater than gases).
- Diffusivities higher than liquids (10<sup>-3</sup> and 10<sup>-4</sup> cm<sup>2</sup>/s).
- Good solvating power.
- Reduction in surface tension.
- Low viscosity (10-100 times less than liquids).
- Gas like compressibility properties, therefore they possess high penetrating power.

The advantages of SCF Extraction are that this process can eliminate organic solvents i.e. it can reduce the risks of storage. This process is also suitable for Extraction and purification of solid or liquid compounds having low volatility. It is also susceptible to thermal degradation (low operating conditions). Also SCF Extraction allows complete separation of solvent from extract and raffinate phase. SCF extraction process is versatile and efficient (use of co-solvents and co-solutes)[39]. The Limitations are Prolonged time (penetration of SCF into the interior of a solid is rapid, but solute diffusion from the solid into the SCF); Compression of solvent requires elaborate recycling measures to reduce energy cost; Scale is not possible due to absence of fundamentals; molecular-based model of solutes in SCF; Cleaning will be time consuming; Maintaining pressure in SCF is difficult [39].

Oleoresins, Spice oil, fragrances and flavored products are the natural products that can be extracted by using SCF extraction technique. Also, it is used in decaffeination of coffee and tea, uniform and ultrafine particle production, dyeing of fabrics, drying of aero gels, etc. SCF extraction process is used for cleaning high precision metal components.

### **3. EXTRACTION TECHNIQUES**

Ultrasonic assisted Extraction, Microwave assisted Extraction, Mechano-chemical assisted Extraction, Supercritical Fluid Extraction, Heat Reflux Extraction, Pressurized Liquid/ fluid Extraction, Enzyme assisted Extraction, Soxhlet Extraction and many more are the Extraction techniques. Some of them are discussed further [43].

#### **3.1. Microwave Assisted Extraction Method**

##### *3.1.1. Principle*

Electromagnetic waves consist of two perpendicularly oscillatory fields namely: Electric Field and Magnetic Field, which can also be called as Microwave. These waves are used as energy vectors or information carriers. Electromagnetic waves are absorbed by the material and converted to heat energy. This is a Microwave Energy.

Microwave Energy ranges from 300 MHz to 300 GHz. These waves are non-ionisable radiation [43].

There are two mechanisms for conversion of electromagnetic energy to calorific energy or heat: Ionic Conduction and Dipole Rotation [44].

**Ionic Conduction:** Dispersion of ions under the influence of electric field when electromagnetic field is applied [45]. As there is change in sign of the electric field, the direction of ions changes which results in collisions of molecules with each other and resist the flow of ions. This creates friction and results in heating of solution.

**Dipole Rotation:** When an electric field is applied to the polar molecules (having dipole moment), they try to line up with the electric field. As the electric field decreases, restoring of thermal molecules takes place that in turn leads to release of thermal energy. This release of energy results in heating of solution [46]. The Fig. shows the behavior of polar molecules under the influence of electric field.

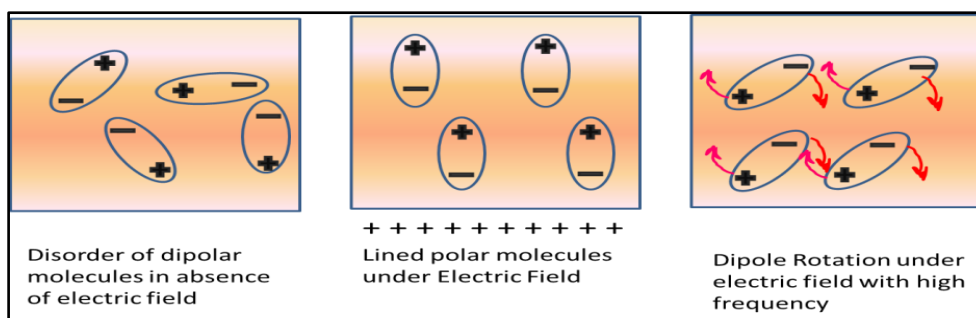
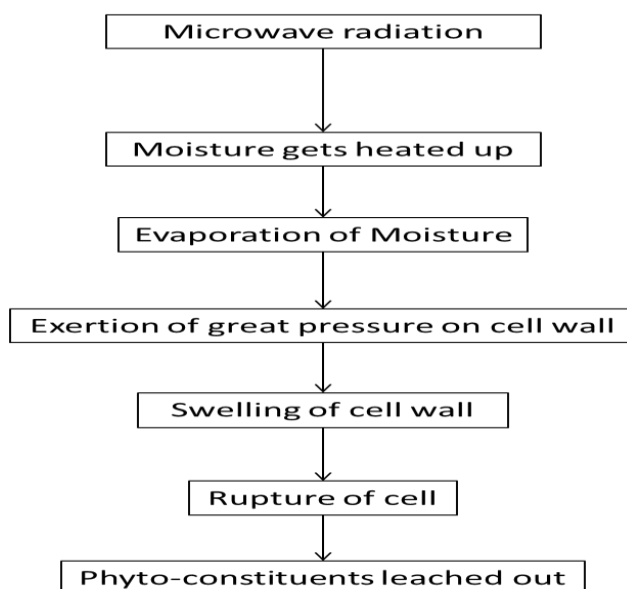

Fig8. Dipole Rotation

### 3.1.2. Process of Microwave Extraction

For Extraction purpose dried plant material is used, so even though it is dried it contains some moisture content. This moisture content gets heated due to microwave incident and the pressure inside increases. The pressure is exerted on the wall of the plant cell and leads to swelling of cell. Further increase in pressure leads to rupture of cell, due to this the components in the cell is leached with the solvent. If plant matrix is saturated with the solvent, the efficiency of heating increases. Focused microwave ovens (only a part of extraction vessel is irradiated) and closed extraction vessels (extraction under controlled conditions), are the two types of instruments used for Microwave Extraction process. Both the system are divided into two types, multi-mode and single-mode.

The following flowchart shows the steps involved in Microwave Extraction process.



### 3.1.3. Factors affecting Microwave Extraction

#### 1) Solvent:

Proper Selection of solvents results in good extraction yield. Solvents such as Dichloromethane, Methanol, Acetone, Petrol Ether, etc. are used for Microwave Extraction process. The Selectivity of solvents towards the analyte should be high. The Extracting solvent should be compatible with chromatographic steps. The Dielectric properties of solvent and volume of solvent also affect the Process. Hence, optimization of this factor is of primary importance [48].

#### 2) Extraction time:

As the quantity of analytes increases, the extraction time also increases. This also results in the increase in risk of degradation, after particular extraction time or recovery; further extraction will lead to degradation of essential constituents. For different plant matrix used the extraction time is different [48].

#### 3) Microwave power:

Adequate amount of Microwave power should be supplied, it should not be much more than needed and much less than required. This depends on the Extraction efficiency based on power and its time of exposure. Optimization is done based on trial and error methods, with its experimental data [48].

#### 4) Matrix characteristics

Particle size (Extracted material): 100 $\mu$ m-2mm.

Finer the particle, larger the surface area, more effective extraction. So size of the matrix and the amount of initial moisture in the matrix are the factors that affect the process [48].

#### 5) Temperature and Pressure:

The increase in solvent results in increase in solubility and decrease in surface tension and solvent viscosity. Leaching of phyto-constituents into the matrix, leads to high extraction recovery. As pressure is dependent on temperature, so pressure is also an important factor to be considered [48].

##### 3.1.4. Application of Microwave Extraction process

Following are the compounds that can be extracted using this process[50].

Volatile oils – Matrix: *Mentha piperits*, *Thuja occidentalis*, System: Modified Domestic Oven. The Extraction takes place with the help of transparent solvents.

Ethanol – Matrix: leaves of *Pistacia lentiscus* and *Cyclocarya paliurus*, System: Open and Closed Vesel respectively. For open vessel the extraction is carried out at power 600W.

Acetone – Matrix: Fruits of *Citrus seninsus*, System: Open vessel.

##### 3.1.5. Advantages and Disadvantages of Microwave Extraction process.

The main advantage of Microwave Extraction is that the Extraction time required for this process is less, also the solvent required is less, the Equipment cost is low and recovery of solvent is moderately high for this process [49].

The main Limitation is that, after the process, remains of solid residue exist in the extractor. So, additional process of centrifugation and filtration is necessary to facilitate removal of solid residue. The non -polar solvents cannot be applicable for processing. Also, the volatile solvents cannot be used for this process as it reduces the efficiency for Microwave extraction process [49].

## 3.2. Soxhlet Extraction

It is a continuous solid/ liquid extraction. The solid material which is to be extracted is placed in thimble which is made of a material such that it contains solids but allows only liquids to pass through it (It acts as a filter paper).The thimble is then placed in extractor. Organic solvent is then heated in reflux due to which the vapors generated starts boiling and as the vapor rises up they are further condensed by the condenser which further fills up the thimble. This process is repeated until all the materials which is to be extracted from the solids is done [37].

Soxhlet Extractor consist of the following apparatus [54],

- 1) Soxhlet Extractor
- 2) Mantle Heater (Electric)
- 3) Water Condenser
- 4) Flash Evaporator

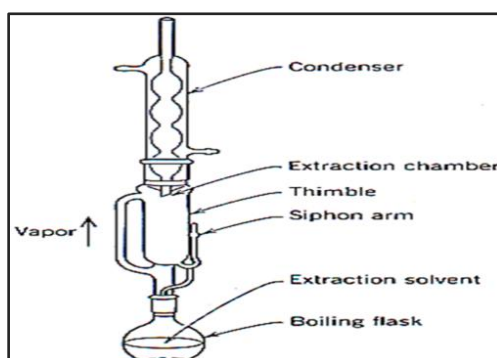

**Fig9.** Soxhlet extraction apparatus

The solid material which is to be extracted is placed inside a thimble which is made from a thick filter paper which is further passed into the main chamber of the Soxhlet extraction. These equipment is further equipped with a condenser. When the vapor is heated in a mantle heater due to which the vapor rises up the chamber which is cooled with the help of condenser equipped to it [54]. The condenser ensures recycle of solvent back in to the chamber. The chamber containing the solid material is slowly recycled with the warm solvent. When the Soxhlet extraction chamber is fully filled it is automatically emptied by a siphon arm. These are repeated many times an hour or a day till the solid is not extracted upto a desired level [54].

It is most widely used for solid liquid extraction in various fields such as pharmaceuticals, environment and foodstuffs.

It is most common method and used as a reference and standard method in many laboratories for extraction of oil from different materials [37].

Good solvent recovery capacity, inexpensive system and ease to handle and operate the system are some of the advantages of the system [37, 54]. Though this technique is simple but there are few drawbacks to Soxhlet extraction such as long drying, and the amount of time and solvent required is more (8 hr), and (200ml) respectively, lack of automation. Another error with this method is that the solvent should be heated so that it is boiled and the vapors starts to evaporate, but at the same time the temperature of the heating medium should be as low as possible to minimize decomposition of extracted solutes and also to avoid unnecessarily loss of solvent [37,54].

### **3.3. Pressurized Liquid Extraction (PLE)**

#### *3.3.1. Principle*

Pressurized Liquid Extraction is done at high temperature and high pressure. These conditions maintain the solvent in liquid state. The value of temperature and pressure of solvents is less than the critical temperature and pressure [52]. This technique is also called as Accelerated solvent extraction or Pressurized hot solvent extraction or Pressurized fluid extraction.

PLE is the fast process than the conventional extraction technique. Solvents required are significantly less than in conventionally used process. At high temperature and high pressure the properties of solvents are changed. There is increase in mass transfer rates, increase in solubility of analyses and decrease in surface tension and viscosity. Such conditions result in better extraction rates.

#### *3.3.2. Factors affecting PLE process*

Solvents should be wisely selected on their specificity and also should be environment friendly. Safe solvents such as ethanol, ethyl lactate or d-limonene are preferred. The most ecofriendly solvent used is water.

Temperature and Pressure are the most important factors that help to maintain the solvent in liquid state. Further increase in pressure above a point, do not significantly affect the results. Typically employed pressure is between 5 to 10MPa.

After extraction temperature and pressure, extraction time is another factor that has be considered and optimized. At a particular extraction temperature and pressure, the time of close contact between the solvent and the matrix is called the effective extraction time. For example, extraction time for bioactive extraction from natural sources is 5 to 20 min [51]. This parameter should be optimized with several experiments. Beyond effective extraction time the extraction efficiency do not increase.

Several other parameters like sample particle size, mass transfer rate, etc. also should be considered [51, 52].

Dispersants are also introduced with the sample to the extraction cell. This ensures uniform solvent distribution and greater yield of extraction.

#### *3.3.3. Equipment used of PLE process*

Following are the equipments used in Pressurized liquid extraction process:[51]

1) Pump

- 2) Extraction cell
- 3) Oven
- 4) A Collection tube or Collection vial

Solvent is feed to the system with the help of pump. This pump should withstand the selected pressure. Another function of the pump is to sweep or push away the extract after the process. In the Extraction cell the extraction process occurs. The cell works at high pressure and is equipped with on and off valves. The oven heats the extraction cell to the desired temperature. The maximum working temperature is about 200°C. Collection vial collects the sample from the extraction cell[51].

Heating coils can also be used for heating solvents in dynamic extraction conditions. Also Nitrogen can be equipped to vent solvent after extraction. Corrosive resistive materials are used in construction of instruments.

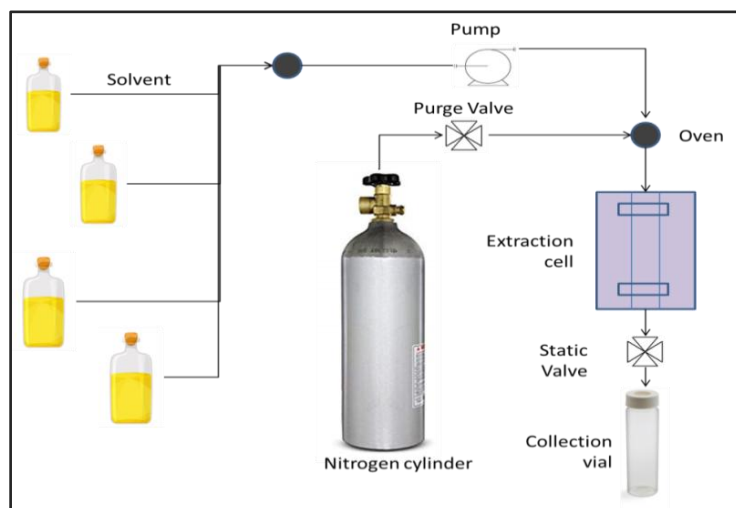

**Fig10.** PLE process

### **3.4. Ultrasound extraction (sonication)**

#### *3.4.1. Principle*

This process involves the use of ultrasound with frequencies ranging from 20KHz to 2000KHz; these increases the permeability of the cell and produces cavitations.

Although these process is useful in many cases like extraction of anthocyanins and antioxidants and also it is useful in the field of nanotechnology; it is also used in extraction of ruwolfia root, but it is limited dur to its high cost.

#### *3.4.2. Advantages and Disadvantage*

The advantages of Ultrasound Extraction includethe increase of extraction yield and also involve faster kinetics and reduction in the operating temperature allowing the extraction of thermolabile compounds. Material used are of small amount, efficient and minimize the expenditure of solvents, with increase in throughput of the sample [43].Ultrasound Extraction technique is also efficient in recover and purification of active ingredients [43].Compared with other novel extraction techniques such as microwave-assisted extraction, the ultrasound apparatus is cheaper and its operation is easier.

One of the disadvantages of these procedure is the occasional but known deterious effect of ultrasound energy (more than 20KHz) on the active constituents of medical plants through formation of free radicals and consequently undesirable changes in drug molecules.

#### *3.4.3. Application*

Ultrasound extraction is used in crude oil desulfurization and cell disruption. Sonication can also be used to initiate crystallization processes and even to control polymorphic crystallization. This method is also used in production of biofuels, production of nanoparticles such as Nano emulsion and liposomes as well as for waste water purification extraction of plant oil.

#### **4. COMPARISONS OF EXTRACTION TECHNIQUES**

For recovery of an organic compounds from sample of a solid matrices there are comparisons mentioned further for different extraction process.

In Soxhlet type of extraction, the extraction time needed is 6 to 24 hrs per sample for sample mass of about 10gm. Solvents (consumption- 150-300ml) Acetone and Hexane, Acetone/DCM are used in 1:1 proportion (vol/vol). For solvents such as toluene and methanol the proportion used is 10:1 per sample (vol/vol). Extraction here is done by heating process. Basically this process is a consecutive process but for multiple assemblies the can be operated continuously. The time needed for development of this method is low, also equipment and operator skills required are very low.

Rather the Extraction time needed for Ultrasonic assisted Method or Sonication process is less comparatively to Soxhlet Extraction Method. For 2-30gm sample mass, extraction time needed is 3-5 min per sample. Here all the combinations of solvents used are of equal proportions. Solvents consumption are of less quantity, approx. 5-20ml. Extraction methods are proceeded with Ultrasound method. Ultrasound Method of Extraction can be performed for Batch and Continuous process both. Like Soxhlet Extraction Sonication method development time, operator skills and equipment cost is low.

The Supercritical Fluid Extraction uses Carbon dioxide as a solvent. For 1-10gm of sample mass to extract, the Extraction time is 30min to 1 hour per sample. Solvent consumed are 10-20ml and extraction method include heat and pressure. Only Batch Operations are performed in this process. Operator skill, cost of the equipment and the time needed to develop this method is high as compared to the above two methods.

For 2-10gm of sample mass, the extraction time needed for Microwave assisted Extraction 50min for up to 40 samples. Solvent consumption is about 25-45ml. Like Supercritical Fluid Extraction, methods of heat and pressure are equipped in this technique. Maximum 40 systems can be extracted simultaneously in this process. Time of development of this process is high as compared to other process. Rather the operator skills and instrument cost are moderate.

For Pressurized Fluid Extraction, the extraction time is about 12-15 min for 30gm sample mass. Various types of solvent combinations with varying proportions are used in this technique. Extraction here is done with the help of heating and pressurizing and solvent consumption is about 25ml. Both batch and continuous combinations are used in this method. Instrument cost and time of development of the process is high and the operator skills required are low.

#### **5. CONCLUSION**

In Industries Extraction process plays a key role in separation of desired components from its mixture using a suitable solvent. Extraction has great applications in almost all industries such as Chemical, Pharmaceuticals, Effluent treatment, Polymer, Petroleum, Petrochemicals, Food, Metal, Inorganics, Nuclear, etc, so it difficult for any process to occur without extraction process. Depending upon the properties of materials to be extracted it is essential to study the extraction methods in detail.

#### **ACKNOWLEDGEMENT**

No review is ever complete without the guidance of experts, who have already traded this field before and hence become the master of it. So, we would like to take this opportunity to take all those individual into account who have helped us in visualizing this content. We also owe a deep sense of gratitude to the Department of Chemical Engineering for their esteemed and unconditional support. Overwhelmed with emotions we would like to thank our parents who gave us and eternal feeling to do this work.

#### **REFERENCES**

- [1] Liquid-Liquid Extraction Chemistry, *LibreTexts*, 2013-10-25.
- [2] Kister, Henry Z, (1992), "Distillation Design (1st ed.)", *McGraw-Hill*, ISBN 0-07-034909-6.
- [3] A B Perry, R.H, Green, D.W. (Editors) (1997), "Perry's Chemical Engineers' Handbook (7th ed.)", *McGraw-Hill*, ISBN 0-07-049841-5.
- [4] Seader, J. D. & Henley, Ernest J. (1998), "Separation Process Principles", *New York: Wiley*, ISBN 0-471-58626-9.

- [5] DePriester, C. L. (1953), "Chem. Eng. Prog", *Symposium Series*, 7, 49, pages 1-43.
- [6] Handley AJ, (1999), "Extraction Methods in Organic Analysis", *ShefReId: ShefReId Academic Press*.
- [7] Karger BL, Snyder LR, Horvath C, (1973), "An Introduction to Separation Science", *New York: John Wiley & Sons*.
- [8] Lide DR, (1994), "Handbook of Organic Solvents", *BocaRaton: CRC Press*.
- [9] Morrison GH, Freiser H, (1957), "Solvent Extraction in Analytical Chemistry", *New York: John Wiley & Sons*.
- [10] Perry RH, Green DW, (1997), "Perry's Chemical Engineer's Handbook", 7th edn, *New York: McGraw-Hill*.
- [11] Rydberg J, Musikas, Choppin GR, (1992), "Principles and Practice of Solvent Extraction", *New York*.
- [12] Marcel-Dekker, Wolf FJ, (1969), "Separation Methods in Organic Chemistry and Bio chemistry", *New York: Academic Press*.
- [13] Birajdhar, S. D., Rajagopalan, S., Sawant, J.S., Padmanabhan, S., "Continuous countercurrent liquid-liquid extraction method for the separation of 2,3-butanediol from fermentation broth using n-butanol and phosphate salt", *Process Biochemistry* 50 (2015) 1449-1458.
- [14] Liu, J., Xie, J., Ren, Z., Zhang, W., "Solvent Extraction of phenol with cumene from wastewater", *Desalination and Water treatment* 51 (2013) pp 19-21
- [15] Mizzi, B., Meyer, M., Prat, L., Augier, F., Leinenkugel-le-cocq, D., "General design methodology for reactive liquid-liquid extraction: Application to dicarboxylic acid recovery in fermentation broth", *Chem. Eng. Process* (2016).
- [16] McCabe, W.L. and J.C. Smith, "Unit Operations of Chemical Engineering", 3rd Edition, *McGraw-Hill*, 1976. pp. 619-637.
- [17] McCabe, W.L., J.C. Smith, P. Harriott, "Unit Operations of Chemical Engineering", 5th Edition, *McGraw-Hill*, 1993. pp. 623-641.
- [18] Seader, J.D. and E.J. Henley, "Separation Process Principles", *John Wiley*, 1998, pp. 436-438, 443-448.
- [19] Treybal, R.E., "Mass-Transfer Operations", 3rd Edition, *McGraw-Hill*, 1987 (reissue). pp. 477-553.
- [20] Treybal, R.E. (2007), "Liquid Extraction", *Pierce Press*, ISBN 978-1406731262, Oakland.
- [21] Astarita, G, (1967), "Mass Transfer With Chemical Reaction", *Elsevier Publishing Co*, Amsterdam.
- [22] Barbulescu A. & Koncsag C, (2007), "A new model for estimating mass transfer coefficients for the extraction of ethanethiol with alkaline solutions in packed columns", *Appl. Math. Model*, Elsevier, 31(11), 2515-2523, ISSN 0307-904X.
- [23] Hennion, Marie-Claire (1999). "Solid-phase extraction: method development, sorbents, and coupling with liquid chromatography". *Journal of Chromatography A*. 856 (1-2): 3-54.
- [24] Augusto, Fabio, Hantao, Leandro W., Mogollón, Noroska G.S., Braga, Soraia C.G.N, (2013), "New materials and trends in sorbents for solid-phase extraction". *TrAC Trends in Analytical Chemistry*. 43: 14-23.
- [25] Abdel-Rehim, Mohamed (2011), "Microextraction by packed sorbent (MEPS): A tutorial ", *Analytical Chimica Acta*. 701 (2): 119-128.
- [26] M. Abdel-Rehim, AstraZeneca, Application "Syringe for solid phase micro extraction", *Current Patents Gazette*, week 0310, WO 03019149, p. 77, (2003).
- [27] Mitra, Somenath, ed. (2003), "Sample Preparation Techniques in Analytical Chemistry", *Wiley-Interscience*. p. 113.
- [28] del-Nabi IM, Kadry AM, et al. "Development and validation of a high-performance liquid chromatographic method for the determination of benzophenone-3 in rats". *J Appl Toxicol*, 1992;12(4):255-9.
- [29] Martin PD1, Jones GR, Stringer F, Wilson ID, "Dept. of Drug Metabolism and Pharmacokinetics", *AstraZeneca Pharmaceuticals*, Mereside, Alderley Park, Maccles field, Cheshire, UK SK10 4TG. *Analyst*. 2003 Apr; 128(4):345-50.
- [30] Andrasi, N., Helenkar, A., Vasanits-Zsigrai, A., Zaray, G., Molnar-Perl, "The role of the acquisition methods in the analysis of natural and synthetic steroids and cholic acids by gas chromatography-mass spectrometry", *J. Chromatogr., A*, 2011, 1218, 8264-8272.
- [31] Arditoglou, A., Voutsas, "Determination of phenolic and steroid endocrine disrupting compounds in environmental matrices", *Environ. Sci. Pollut. Res.*, 2008, 15, 228-236.
- [32] Oliva P, Canencia, angelo Mark P, Walag (2016), "Coal Combustion from Power Plant Industry Inmisamis Oriental, Philippines: a Potential Groundwater Contamination and Heavy Metal Detection", *Asian Journal of Microbiology, Biotechnology & Environmental Sciences*. 18 (1): 55-59. ISSN 0972-3005.
- [33] Geankoplis, Christie (2004), "Transport Process and Separation Principles", *NJ: Pretence Hall*, pp. 802-817. ISBN 978-0-13-101367-4.

- [34] Seader and Henley, J.D. and Ernest J, (2001), "Separation Process Principles", U.K: John Wiley & Sons inc. pp. 639–641. ISBN 978-0-471-46480-8.
- [35] Li, Li, Jing Ge, Renjie Chen, Feng Wu, Shi Chen, Xiaoxiao Zhang, (March 16, 2010), "Environmental friendly leaching reagent for cobalt and lithium recovery", International Journal of Integrated Waste Management, *Science and Technology Waste Management*, 30 (12): 2615–2621.
- [36] Li, Li, Jing Ge, Feng Wu, Renjie Chen, Shi Chen, Borong Wu (2010-04-15), "Recovery of cobalt and lithium from spent lithium ion batteries using organic citric acid as leachant", *Journal of Hazardous Materials*, 176 (1–3): 288–293.
- [37] John R. Dean, Extraction techniques in Analytical Sciences, The Graduate School and School of Applied Sciences Northumbria University, Newcastle, UK.
- [38] G. N. Sapkale, S. M. Patil, U. S. Surwase, P. K. Bhatbhave, "Super Critical Fluid Extraction", *ASPM, S. K. T. Patil College of Pharmacy*, Osmanabad, India.
- [39] Abbas, K.A., A. Mohamed, A.S. Abdulmir and H.A. Abas, "A Review on Supercritical Fluid Extraction as New Analytical Method", *Faculty Food Science and Technology*, University Putra Malaysia (UPM), Malaysia.
- [40] Bravi, E., G. Pperretti, L. Motanari, F. Favati and P. Fantozzi, 2007, "Supercritical fluid extraction for quality control in beer industry", *J. Supercrit. Fluids*, 42: 342-346.
- [41] Yoshiaki Fukushima, "Application of Supercritical Fluid", *R & D Review of Toyota CRDL*.
- [42] Clifford, Tony, Fundamentals of Supercritical Fluids, Oxford Science Publications, Oxford (1999).
- [43] Ankit Gupta, Madhu Naraniwal & Vijay Kothari, "Modern Methods of Extraction for Preparation of Bioactive Plants", *Institute of Science, Nirma University*, Gujarat, India.
- [44] Emilie Destandau,\* Thomas Michel, Claire Elfakir, "Microwave Assisted Extraction", *Institut de Chimie Organique et Analytique, Université d'Orléans-CNRS UMR 7311, BP 67059, 45067 Orléans cedex 2, France*.
- [45] C. Sparr Eskilsson and E. Bjo" rklund, *J. Chromatogr. A*, 2000, 902, 227.
- [46] V. Camel, *Trends Anal. Chem.*, 2000, 19, 229.\
- [47] K. Ganzler, I. Szinai and A. Salgo', *J. Chromatogr. A*, 1990, 520, 257.
- [48] P. Tatke, Y. Jaiswal, "An Overview of Microwave Assisted Extraction and its Applications in Herbal Drug Research",
- [49] Farid Chemat, Giancarlo Cravotto, 2012, Microwave-assisted Extraction for Bioactive compounds: Theory and Practice", *Food Engineering Series*.
- [50] Mauricio A. Rostagno, Juliana M. Prado, 2013, Natural Product Extraction: Principles and Applications".
- [51] Dean, J. R., "Methods for Environmental Trace Analysis", AnTS Series, *John Wiley & Sons Limited*, 2003.
- [52] K. Duarte, Armando C. Duarte, "Analysis of Marine Samples in search of Bioactive Compounds", *Comprehensive Analytical Chemistry*, 2014.
- [53] Numata, M., Yarita, T., Aoyagi, Y., Tsuda, Y., Yamazaki, M., Takatsu, A., Ishikawa, K., Chiba, K. and Okamaoto, K., *Anal. Bioanal. Chem.*, 387, 2313–2323 (2007).
- [54] NurAtiqah Mohd Shamsuddin, Yusup Suzana, Wan Asma Ibrahim, Awais Bohkari, (2015), "Oil Extraction from Calophyllum inophyllum L. via Soxhlet Extraction Optimization using Response surface technology (RSM)", Kota, Kinabalu.

**Citation:** Dr. Pradnya Ingle, et.al, (2019). Review of Extraction Techniques Extraction Methods: Microwave, Ultrasonic, Pressurized Fluid, Soxhlet Extraction, Etc. *International Journal of Advanced Research in Chemical Science (IJARCS)*, 6(3), pp.6-21. DOI:<http://dx.doi.org/10.20431/2349-0403.0603002>.

**Copyright:** © 2019 Authors. This is an open-access article distributed under the terms of the Creative Commons Attribution License, which permits unrestricted use, distribution, and reproduction in any medium, provided the original author and source are credited.